

CUTLINE

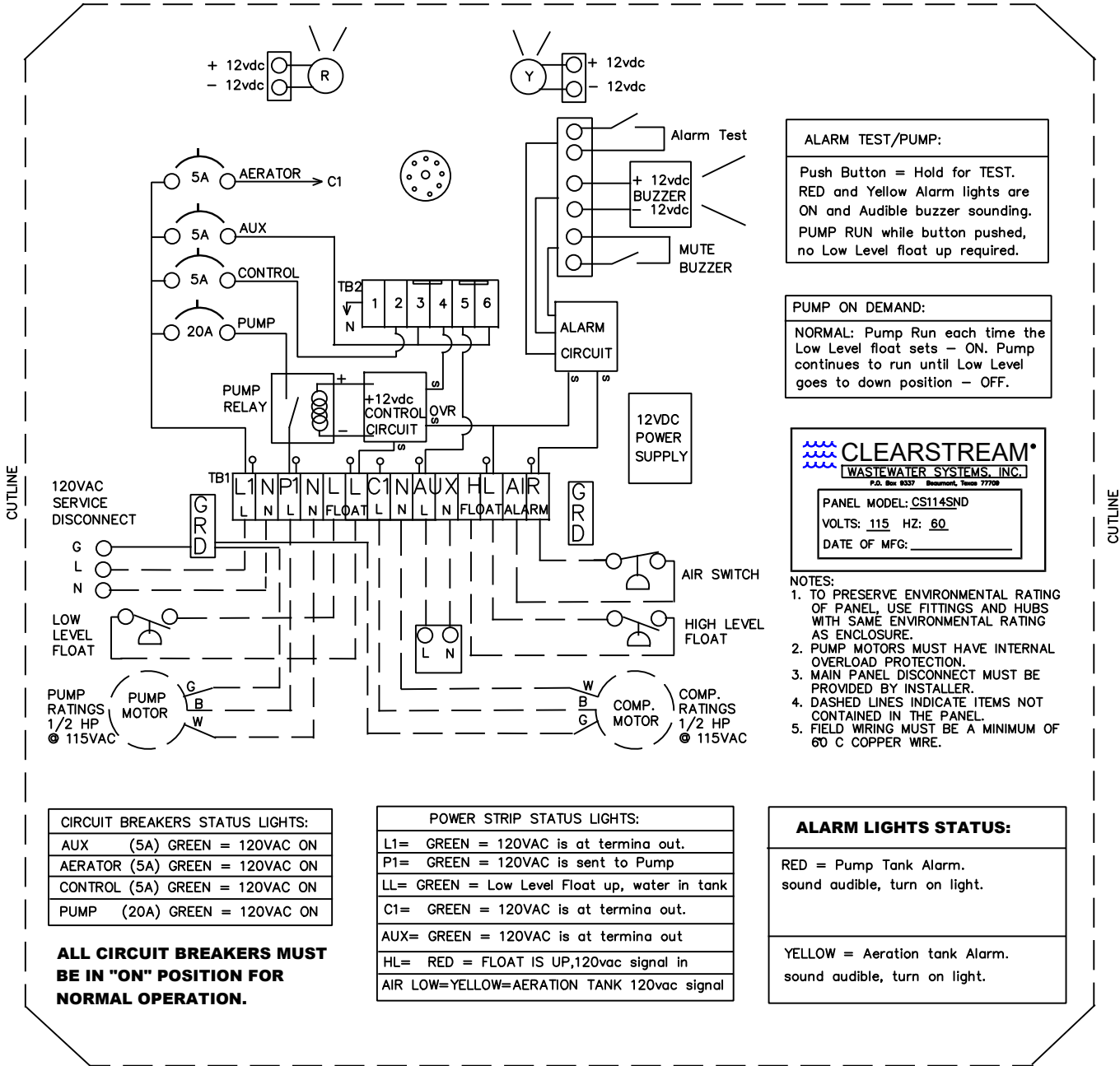

ALARM TEST/PUMP:

Push Button = Hold for TEST.
 RED and Yellow Alarm lights are ON and Audible buzzer sounding.
 PUMP RUN while button pushed, no Low Level float up required.

PUMP ON DEMAND:

NORMAL: Pump Run each time the Low Level float sets - ON. Pump continues to run until Low Level goes to down position - OFF.

CLEARSTREAM®
 WASTEWATER SYSTEMS, INC.
P.O. Box 9327 Houston, Texas 77299

PANEL MODEL: CS114SND
 VOLTS: 115 HZ: 60
 DATE OF MFG: _____

- NOTES:
1. TO PRESERVE ENVIRONMENTAL RATING OF PANEL, USE FITTINGS AND HUBS WITH SAME ENVIRONMENTAL RATING AS ENCLOSURE.
 2. PUMP MOTORS MUST HAVE INTERNAL OVERLOAD PROTECTION.
 3. MAIN PANEL DISCONNECT MUST BE PROVIDED BY INSTALLER.
 4. DASHED LINES INDICATE ITEMS NOT CONTAINED IN THE PANEL.
 5. FIELD WIRING MUST BE A MINIMUM OF 60 C COPPER WIRE.

CIRCUIT BREAKERS STATUS LIGHTS:	
AUX (5A)	GREEN = 120VAC ON
AERATOR (5A)	GREEN = 120VAC ON
CONTROL (5A)	GREEN = 120VAC ON
PUMP (20A)	GREEN = 120VAC ON

ALL CIRCUIT BREAKERS MUST BE IN "ON" POSITION FOR NORMAL OPERATION.

POWER STRIP STATUS LIGHTS:	
L1=	GREEN = 120VAC is at termina out.
P1=	GREEN = 120VAC is sent to Pump
LL=	GREEN = Low Level Float up, water in tank
C1=	GREEN = 120VAC is at termina out.
AUX=	GREEN = 120VAC is at termina out
HL=	RED = FLOAT IS UP,120vac signal in
AIR LOW=	YELLOW=AERATION TANK 120vac signal

ALARM LIGHTS STATUS:	
RED	= Pump Tank Alarm. sound audible, turn on light.
YELLOW	= Aeration tank Alarm. sound audible, turn on light.

CUTLINE