

CLEARSTREAM®

WASTEWATER SYSTEMS, INC.

P. O. Box 7568 • Beaumont, Texas 77726-7568
(409) 755-1500 • Fax: (409) 755-6500 • www.clearstreamsystems.com

**OWNER'S MANUAL • PARTS LIST • OPERATING MANUAL
FLOW DIAGRAM • INSTALLATION INSTRUCTIONS
DESIGN DRAWINGS AND SPECIFICATIONS
SERVICE POLICY • LIMITED WARRANTY**

**MODELS: 500DA 600DA 750/800DA 1000DA
 500DAC 600DAC 750/800DAC2 1200DACD
 500DASC 600DAT
 500DAST 600DAC2
 600DAC3**



NSF/ANSI 40 Class I,
245, 350

INTRODUCTION

The Clearstream System is one of the finest aerobic wastewater systems available today. Our system converts the sewage from your residence or business into a clear, odorless liquid. This high degree of treatment is accomplished at a remarkable low operating cost per month. The system has been simplified over the years to make it as inexpensive to operate and as low in long term maintenance as possible. Homeowners who have lived with the nuisance of a septic odor lingering in their neighborhood will truly appreciate the pleasure of owning a Clearstream System. Clearstream Model DA Systems comply with NSF Standards 40 for Class I residential wastewater treatment systems, 245 for total nitrogen reduction and 350 for onsite residential and commercial water reuse treatment. Standard 350 systems must include Clearstream model CSUV1 on system discharge.

PROCESS DESCRIPTION

There are four basic zones or compartments to this treatment unit. Wastewater enters the aeration chamber of the process tank, where it is mixed with organisms formed during decomposition of organic material in the wastewater, mixing in the chamber is achieved by release of compressed air near the bottom of the chamber through fine bubble diffusion.

A conical shaped clarifier is located internal to the process tank to provide for separation of the solids from the mixed liquor. The mixed liquor passes into the bottom of the clarifier by hydraulic displacement as wastewater enters the aeration chamber. Solids settled from the wastewater are drawn back into the aeration chamber from the bottom of the cone by the hydraulic roll created by the air released in the aeration chamber and are dispersed by the mixing induced by the aerator. An airlift assembly controlled by a timer and solenoid switch borrow air from the aerator to divert a small continuous return of water from the clarifier back to the pretreatment tank. Approximately 7 hours of return is needed for treatment system max flow to provide denitrification. Discharge of the final clarified effluent occurs through a submerged tee assembly located below the clarifier surface to prevent discharge of solids that may float on the surface of the clarifier.

When disinfection is required before final discharge, appropriate disinfection options are available. If used in Std. 350 operation Clearstream Model CSUV1 unit must be installed on discharge.

When properly loaded and maintained, the aforementioned process allows the Clearstream Wastewater Treatment System to provide years of satisfactory service for the consumer. Clearstream Model DA systems met the performance requirements of NSF Standard 245 with a 30 day average of <25mg/l CBOD, <30mg/l TSS and 50% total nitrogen reduction. Actual GCT test results used to determine if Clearstream met Standard 245 requirements averaged <10 mg/l BOD, <10 mg/l TSS and >50% total nitrogen reduction.

OPERATING MANUAL

In the event you experience a problem with your Clearstream Aerobic Wastewater Treatment System or if service is required, you may reference the Clearstream Control Panel Cover for the name, address and phone number of a local service person that can provide service for your Clearstream Unit. After the expiration of your initial two year service policy provided by the system installer, you may obtain a continuing service policy on a yearly basis which will include terms comparable to the initial service policy from a local service person that is trained and certified by Clearstream.

In order for the Clearstream System to function at optimum performance levels, the system will require periodic service. The normally expected service that is associated with the system includes:

1. Repair or replace aerator	2 to 10 years
2. Clean filters on aerator	6 mos. to 2 years
3. Break up scum in clarifier	6 mos. to 2 years
4. Pump sludge from aeration tank	2 to 5 years*
5. Pump sludge from pretreatment tank	2 to 5 years*
6. Check aeration diffusers	annually
7. Check surge control weir	6 mos.
8. Check denite effluent return flow	6 mos.**
9. Replace UV bulb (when UV is installed)	annually

* Any sludge removed from pretreatment tank or Clearstream Unit must be disposed of according to all state, local and federal regulatory requirements.

** Denite return is factory preset. In field adjustments allowed by Clearstream trained professional maintenance personnel only.

To remove solids from pretreatment tank drop pump hose through access opening on top of tank all the way through to the bottom of the tank. Pump out the whole tank volume, then fill the tank back up immediately. To remove solids from aeration chamber, drop hose through access opening in tank all the way to the bottom of the tank. Pump only 1/2 of the total tank volume and fill tank back up with water immediately.

To determine if all system components are functioning properly, look and/or listen to see if the visual/audio alarm system is illuminated or making a buzzing sound. If the alarm is activated, then either the aerator has lost air pressure or the high level float inside the clarifier is indicating a high water level condition. Verification of either condition can be made by checking air pressure from aerator with a pressure gauge and opening the access opening to the treatment unit to see if the water level inside the clarifier is at alarm level. After inspection of the clarifier, be sure to securely fasten the access cover back in place and tighten the tamper resistant bolt or bolts firmly.

To determine if the system has the desirable "mixed liquor" and effluent characteristics, first remove the access cover. Monitor for odors coming from the tank. If the odor is a sweet or a musty smell, the system is operating in a desirable aerobic condition. If the odor is foul or smells like a rotten egg, then the system is operating in an undesirable anaerobic condition. Visually monitor the "mixed liquor" for color. If the color is a brownish color, then it is operating in a desirable aerobic condition. If it is grey or black in color, it is operating in an undesirable anaerobic condition. The system effluent should be clear with very few noticeable light brown solids suspended in the effluent. The effluent should not be dark or turbid in color or clear with great numbers of light brown suspended solids noticeable. After inspection of the system's interior, be sure to securely fasten the access cover back in place and tighten the tamper resistant bolt or bolts firmly.

In the event the alarm panel light and buzzer is activated, call your local servicing dealer whose name, address, and phone number should be affixed to the face of the panel.

To collect effluent samples from a system, a sample port must be added downstream of the effluent discharge. The sample port should be installed so that effluent cannot remain below the discharge water line and build up solids. A sample bottle should be capable of being lowered into the port on a string and laid on its side in the direct flow line of the discharge and removed when full of effluent.

The expected effluent from the system should be less than 25 mg/l CBOD and less than 30 mg/l TSS with a PH range of 6-9 and total nitrogen removal of a minimum of 50%.

For the first two (2) years from the date of installation, your local servicing dealer (from whom you purchased your Clearstream System) will make periodic inspections of your system to make sure it is functioning properly. The dealer will perform necessary maintenance to the system at no charge unless the required maintenance is not warranty related. Pumping of the system is not included. After the first two (2) years, the dealer will offer a continuing service policy for a nominal annual fee. The two (2) year service policy (two service calls per year) and the continuing service policy are minimum requirements of NSF Standards 40 Class I, 245 and 350 certified wastewater treatment systems. If local service requirements are greater than those of these NSF Standards or if the local regulations require others to perform the service on these units, Clearstream's limited warranty will still be honored.

For the Clearstream Aerobic Wastewater Treatment Unit to function properly it must be used for the treatment of domestic wastewater from residences or other waste flows with similar loading characteristics. Typical domestic wastewater consists of the flow from toilets, lavatories, sinks, bathtubs/showers and washing machines. To prevent malfunctions of your Clearstream Unit, the following guidelines should be followed:

1. Any sewage system, whether aerobic or septic, should not have inorganic materials (plastics, cigarette butts, throwaway diapers, feminine napkins, condoms, etc.) that the bacteria cannot consume, discharged into the system.
2. Large amounts of harsh chemicals, oil, grease, high sudsing detergents, discharge from water softeners, disinfectants or any other chemical or substance that kills bacteria should not be discharged into the system.
3. Excessive use of water, over the design flow of the system, or organic overloading in excess of design parameters will cause the system not to perform to its fullest capabilities.
4. The proper operation of this or any other sewage treatment system depends upon the proper organic loading and the life of the micro-organisms inside the system. Clearstream is not responsible for the in-field operation of a system, other than the mechanical and structural workings of the system itself. Field abuse and overloading of the system can only be cured by the user of the system.
5. When wastewater discharge, into a Clearstream Unit, is seasonal or intermittent to a point that the owner wishes to turn off the electricity (for more than three (3) months) to the aerator, no special service is required. However, it is recommended to install a 1/2 lb psi check valve on discharge of aerator to reduce risk of moisture or gas damaging aerator.

CLEARSTREAM INSTALLATION INSTRUCTIONS

Before installation of the Clearstream Treatment Tank, first install a pretreatment tank (septic tank) with a volume of not less than 50% of the gallon per day rating of the Clearstream Unit. Pretreatment tanks shall comply with minimum sizing specifications outlined in the Clearstream specifications section.

UNLOADING/PACKING INSTRUCTIONS:

1. All compressors are packaged to prevent damage during shipping and handling.
2. Please be careful during shipping or handling of the linear or rotary vane compressors they are fragile and can be damaged if dropped from only a short distance. If dropped hard enough the cast aluminum housing may be damaged and render the compressor useless.
3. The most common issue resulting from a linear compressor being handled inappropriately is the safety switch being tripped. Please refer to the repair manual for switch reset instructions if the compressor fails to power up.
4. All control panels are packaged to prevent damage during shipping and handling.
5. Clearstream electrical control panels are fragile and should be handled as such during shipping and handling. All electrical control panels have circuit breakers, lights and electrical connections and many have relays and timers that are all fragile. Components may be replaced if damaged but if the panel enclosure its self is damaged the panel may be rendered useless.

CLEARSTREAM TANK INSTALLATION

1. Prepare an excavation having minimum dimensions of at least one (1) foot larger than the dimensions of the tank. Make sure the depth of the excavation is deep enough to allow gravity flow to the inlet of the system and that the excavation bottom is level. Never install the Clearstream tank deeper than a depth that will require more than a maximum of 18 inches of riser depth. The access cover shall always be above final grade after tank installation. In applications where more than the maximum 18 inches of riser is required, install a lift pump upstream of the Clearstream tank to pump the pretreatment tank effluent to the Clearstream tank at normal grade. In these special applications where a lift pump is required, contact Clearstream for more details as to pump size, maximum dosages and maximum flow rates.

2. Set the Clearstream tank in a prepared excavation that has a solid, level bottom that will eliminate tank settling. The excavation bottom should have no rocks or sharp objects present.

3. When lowering the concrete tank into the prepared excavation use a spreader bar. Only spreader bars and other lifting devices, that have been designed and tested for lifting Clearstream concrete tanks, should be used. Never lift concrete Clearstream tanks unless they are empty of all liquids.

4. Make sure the inlet 4" Sch. 40 PVC pipe is aligned properly to incoming sewage line.

5. For the Clearstream Unit to function properly, the tank must be level. To properly level the tank, lay a three (3) foot level across the tank in several directions. Shift the tank in the hole, as necessary, to make the tank level in all directions. The tank may be slightly out of level, but it should not be out of level enough to cause tank malfunctions.

6. Fill the tank with fresh water, checking periodically to make sure the tank remains level.

7. Connect the 4" Sch. 40 PVC Clearstream inlet pipe to the incoming sewage line. Make sure the incoming sewage pipe is level with or higher than the inlet pipe to the Clearstream Unit. The Clearstream Unit should only be connected to a plumbing system from a wastewater source which has been properly trapped and vented in compliance with State and Local plumbing codes.

8. Back-fill the excavation in layers with back-fill material that will settle properly around the tank. Tamp the back-fill material as each layer is placed around the tank. If necessary, use water to help settle the soil around the tank. Special care should be taken to either tamp soil under where inlet and outlet pipes are bridging the excavation or use some other method of supporting pipes across the excavation. Do not back-fill with heavy chunks of clay or large rocks.

9. Before completing the back-fill, be sure the electrical conduit from the tank to the Control Panel and the air line from aerator to Clearstream Unit has been laid underground.

10. For below normal grade installations a Clearstream 20-inch diameter riser may be used. In no case shall more than 18" of maximum riser depth be used on a Clearstream Unit to bring the access covers above the final grade. All risers must be sealed with an all weather sealant to prevent ground water intrusion before back-fill is completed.

11. Before leaving excavation site, be sure to securely fasten the Clearstream access covers in place with the tamper resistant bolt(s). Tighten bolts firmly to keep unauthorized personnel from gaining access to the inside of tank.

CLEARSTREAM AERATOR AND CONTROL PANEL

1. Mount the Clearstream Control Panel in a location that can be easily noticed by the occupants.

2. Wire 115 Volt, 60Hz power from an electrical disconnect to Clearstream Control Panel. Wire from Control Panel to Clearstream Tank electrical junction box through conduit. Use wiring diagram provided for each version of the Clearstream Control Panel series. All electrical wiring should be installed by a qualified technician in compliance with NFPA 70 for all electrical components, electrical connections, and system installation.

3. Install Clearstream Aerator Model CS103(xxx), as close as practical to the tank, but in no case greater than one hundred (100) feet away. Run 3/4" Sch. 40 PVC air line from aerator connector to the air line connection at Clearstream tank. Be careful to backfill underground air line in manner which will not cause air line to leak. Aerator must be installed in a location that is dry, non-dusty and highly ventilated.

COMPLIANCE WITH LAWS

The Clearstream Unit must never be installed without first obtaining all permits and approval from the local regulatory body. In areas that do not have local control over environmental activities, all applicable State and Federal environmental codes must be adhered to as well. Only properly licensed and trained individuals should install Clearstream equipment. The effluent from the system should only be utilized for disposal as described in NSF/ANSI Standard 40 and as is in compliance with all local, state and federal requirements. Special care should be taken when installing a unit to prevent cross connections and protect against backflow to potable water supplies.

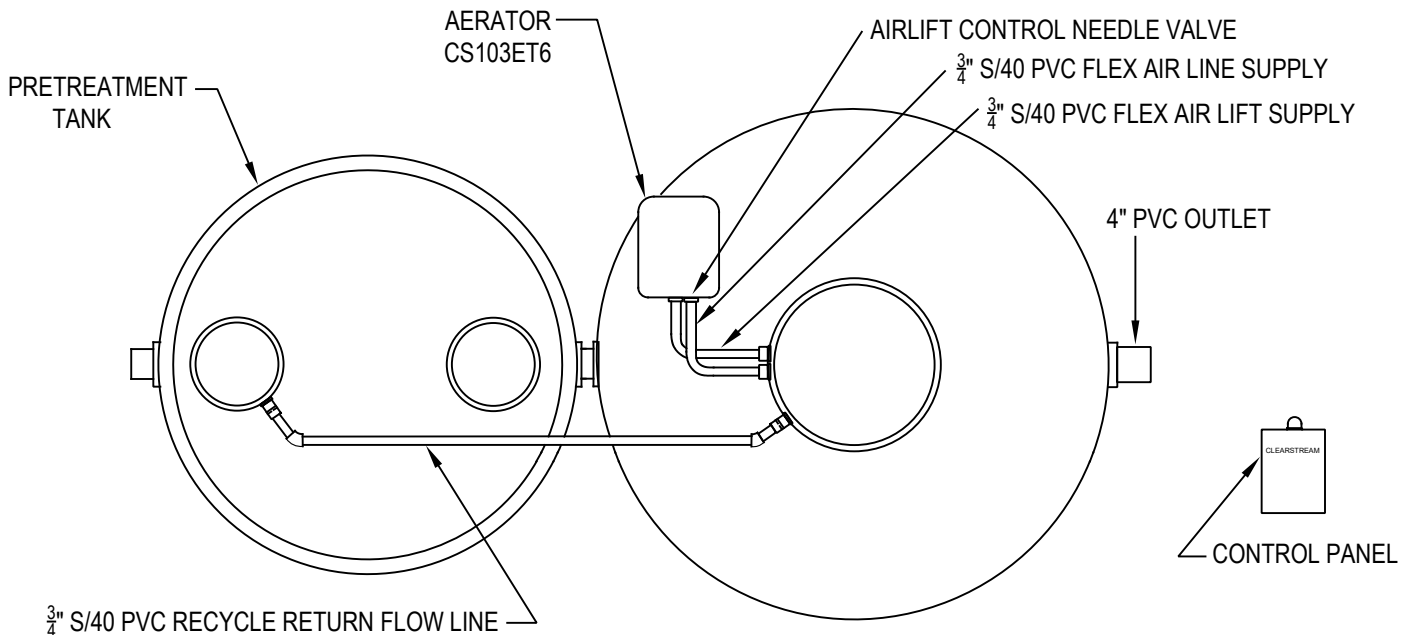

PLAN

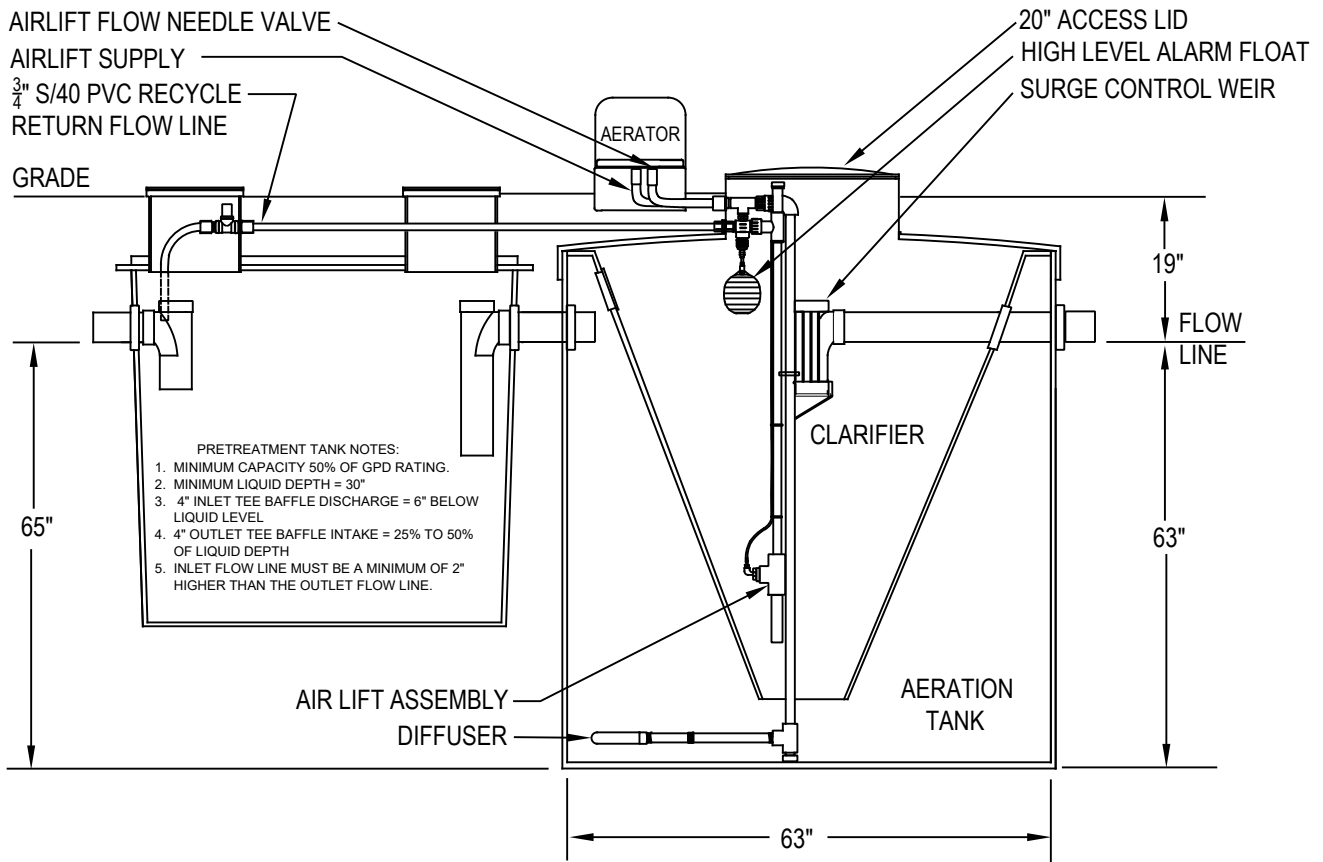

SECTION

- PRETREATMENT TANK NOTES:
1. MINIMUM CAPACITY 50% OF GPD RATING.
 2. MINIMUM LIQUID DEPTH = 30"
 3. 4" INLET TEE BAFFLE DISCHARGE = 6" BELOW LIQUID LEVEL
 4. 4" OUTLET TEE BAFFLE INTAKE = 25% TO 50% OF LIQUID DEPTH
 5. INLET FLOW LINE MUST BE A MINIMUM OF 2" HIGHER THAN THE OUTLET FLOW LINE.

PROPRIETARY AND CONFIDENTIAL THE INFORMATION CONTAINED IN THIS DRAWING IS THE SOLE PROPERTY OF CLEARSTREAM. ANY REPRODUCTION IN PART OR AS A WHOLE WITHOUT THE WRITTEN PERMISSION OF CLEARSTREAM IS PROHIBITED.	DRAWN BY RC	DATE 6/05/2021	<h1>500DA</h1>	
	CHECKED	DATE		
	SCALE NTS	SHEET 1 OF 1	DWG. NO. 500DA rev3	P.O. Box 7568 Beaumont, Texas 77726-7568

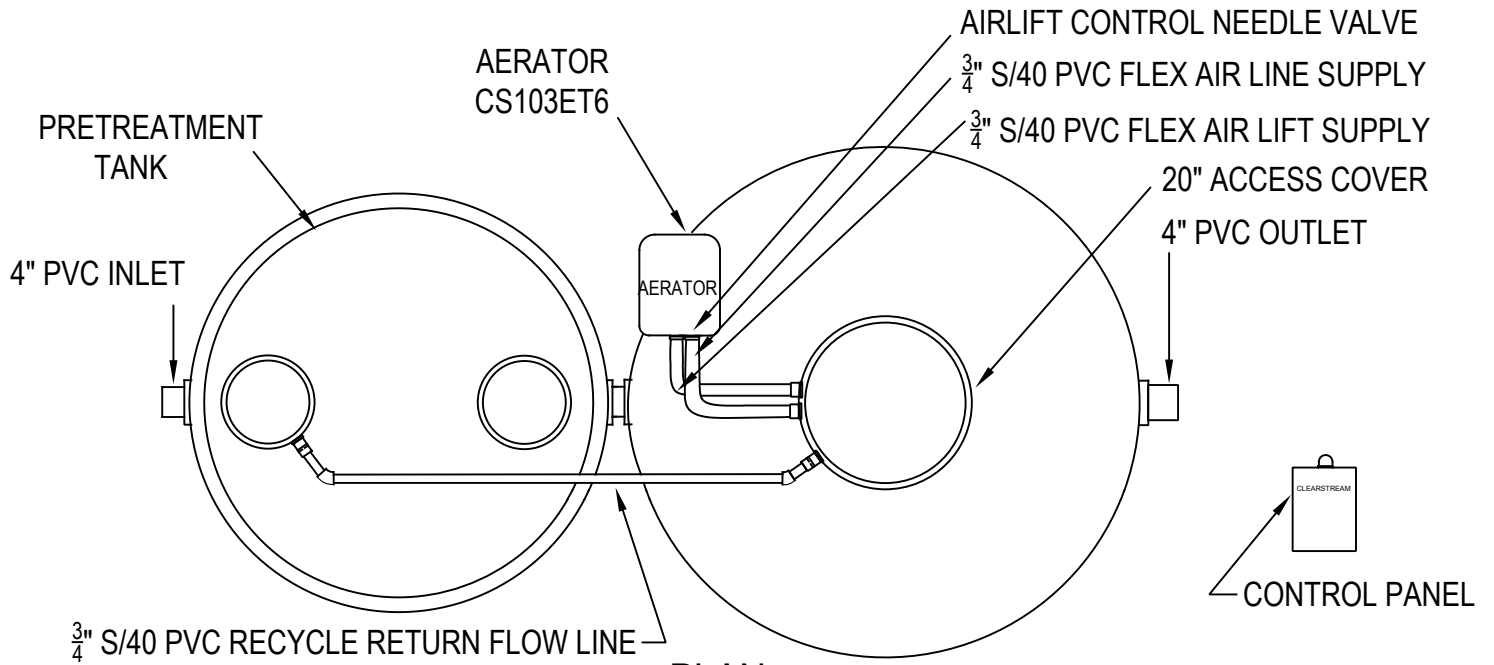

PLAN

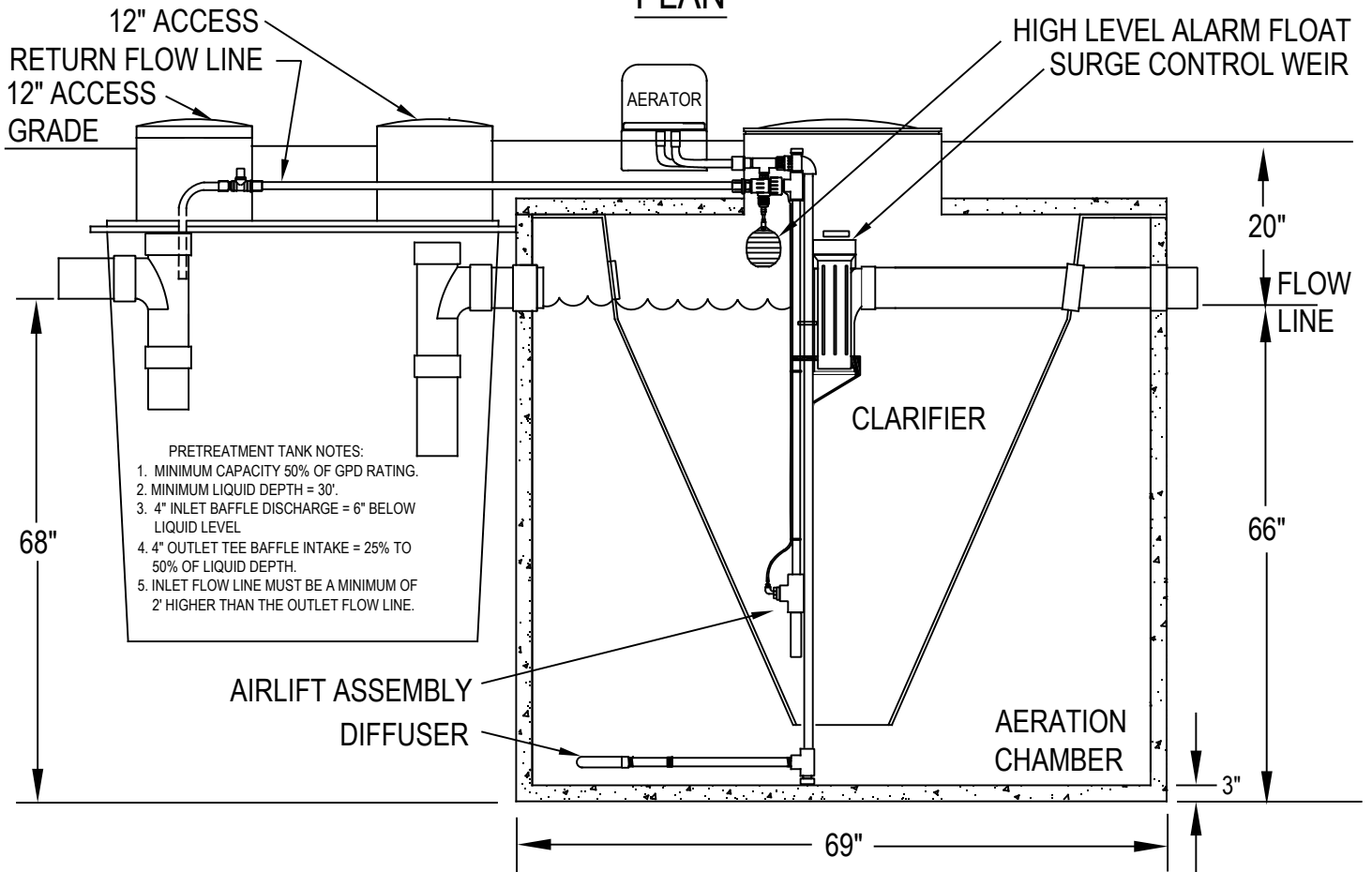

SECTION

PROPRIETARY AND CONFIDENTIAL THE INFORMATION CONTAINED IN THIS DRAWING IS THE SOLE PROPERTY OF CLEARSTREAM. ANY REPRODUCTION IN PART OR AS A WHOLE WITHOUT THE WRITTEN PERMISSION OF CLEARSTREAM IS PROHIBITED.	DRAWN BY RC	DATE 6/05/2021	500DAC		
	REVISED	DATE 6/10/2021			DWG. NO. 500DAC rev3
	SCALE NTS	SHEET 1 OF 1			P.O. Box 7568 Beaumont, Texas 77726-7568

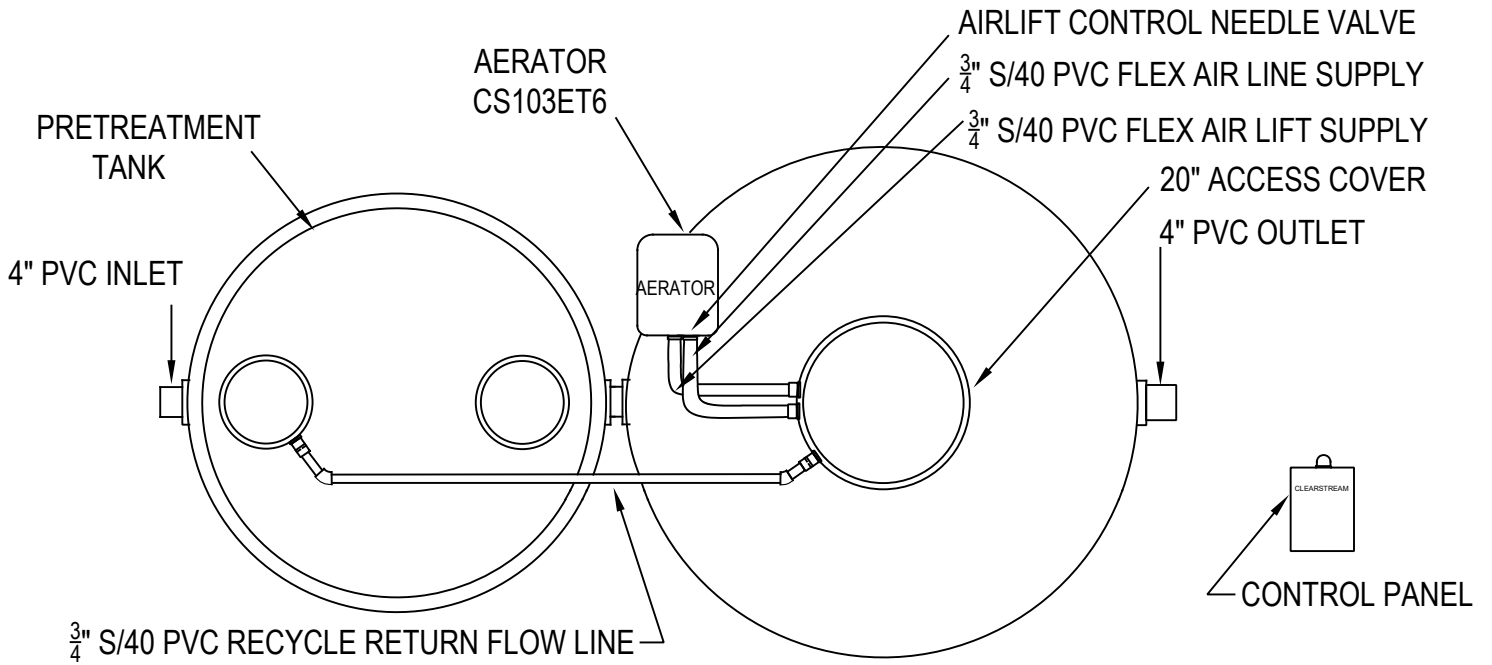

PLAN

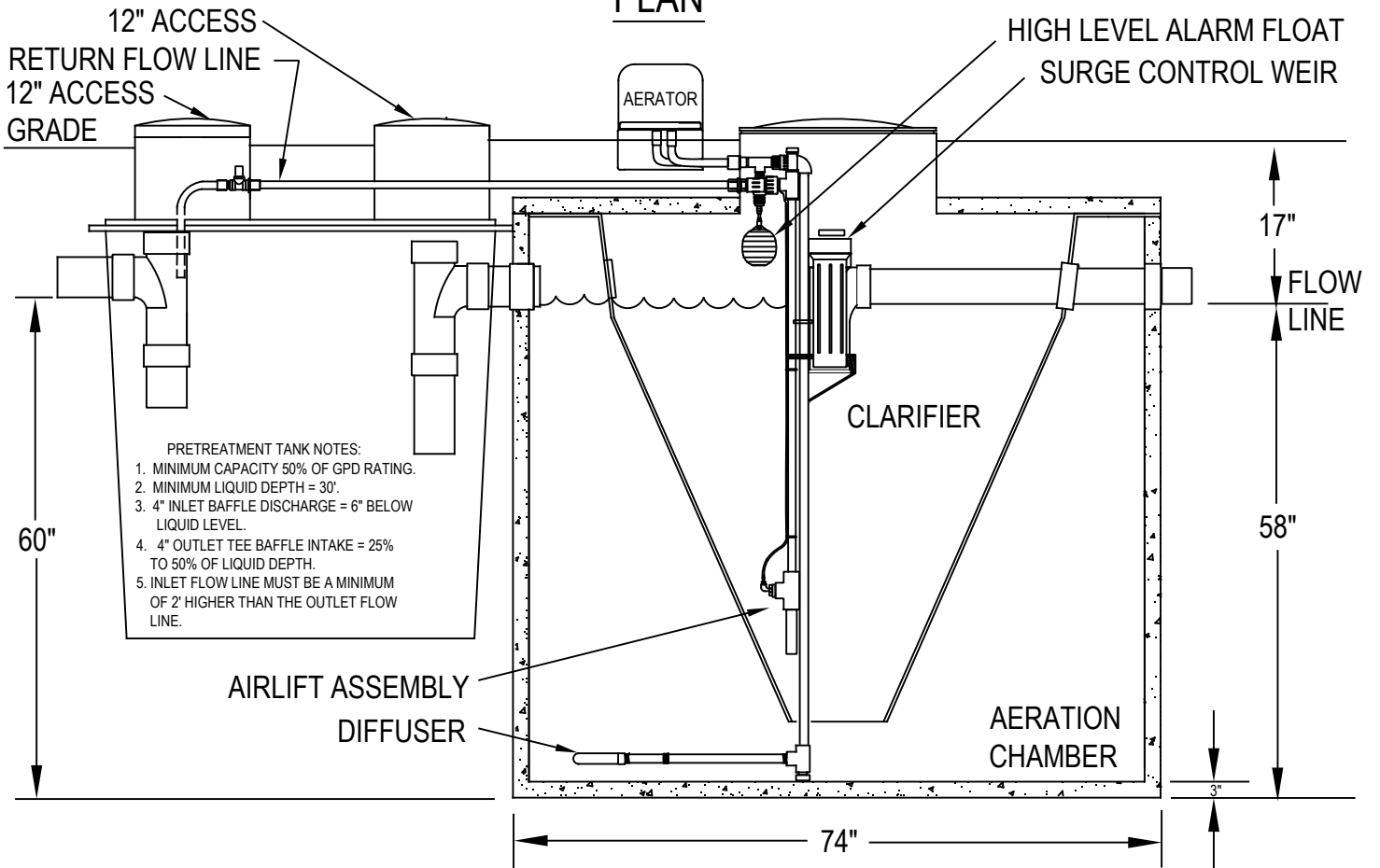

SECTION

PROPRIETARY AND CONFIDENTIAL THE INFORMATION CONTAINED IN THIS DRAWING IS THE SOLE PROPERTY OF CLEARSTREAM. ANY REPRODUCTION IN PART OR AS A WHOLE WITHOUT THE WRITTEN PERMISSION OF CLEARSTREAM IS PROHIBITED.	DRAWN BY RC	DATE 6/05/2021	500DASC DWG. NO. 500DASC rev3	
	REVISED	DATE 6/10/2021		
	SCALE NTS	SHEET 1 OF 1		
P.O. Box 7568 Beaumont, Texas 77726-7568				

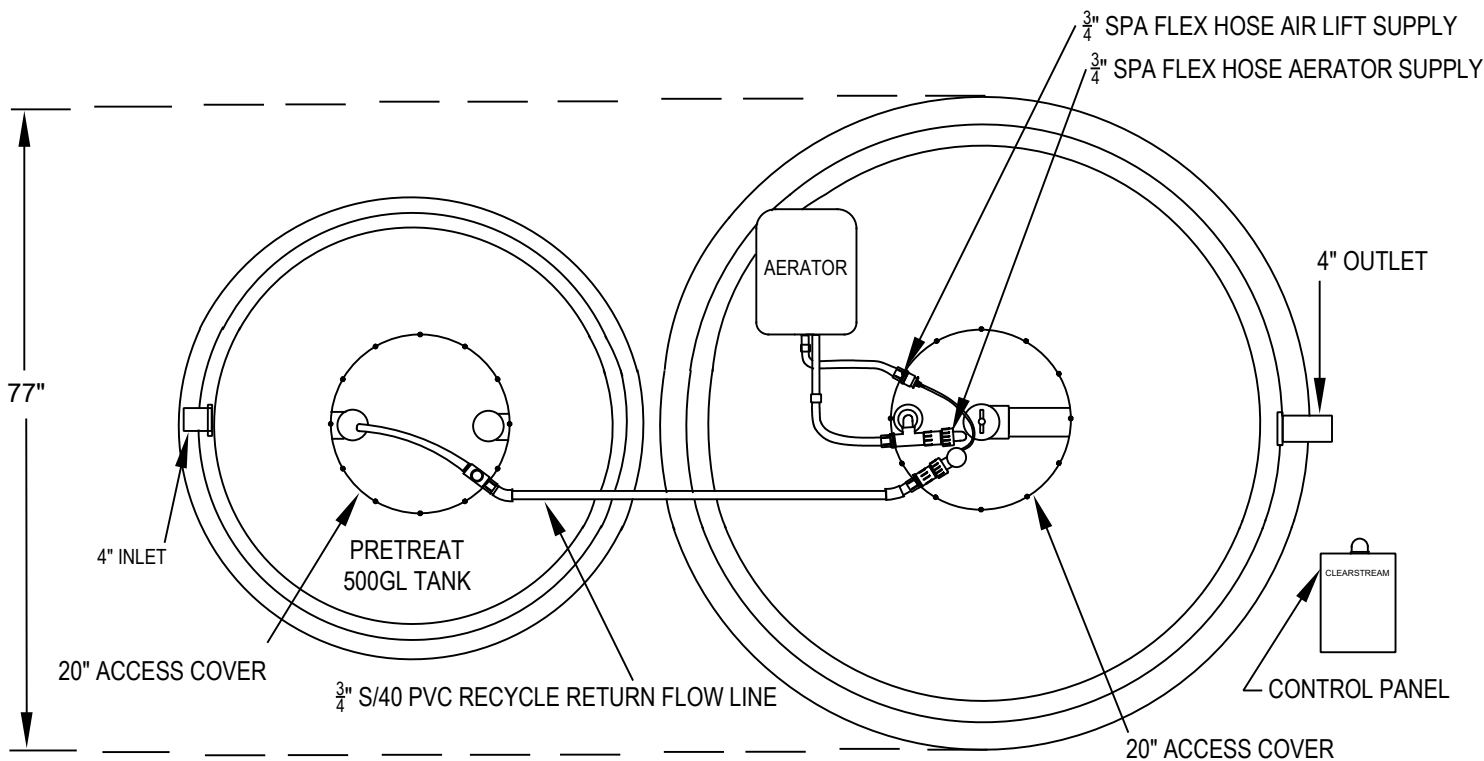

PLAN

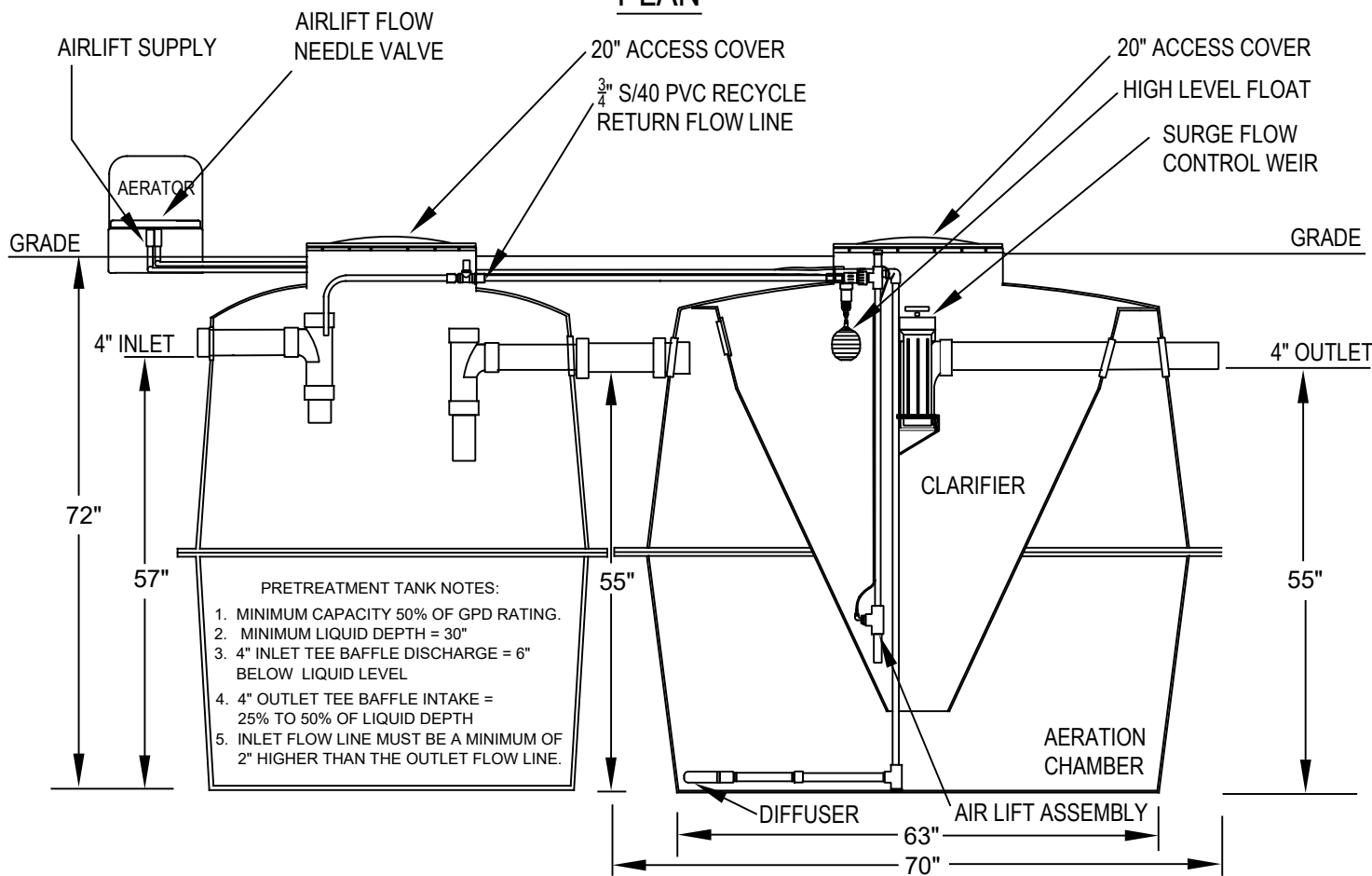

SECTION

- PRETREATMENT TANK NOTES:**
1. MINIMUM CAPACITY 50% OF GPD RATING.
 2. MINIMUM LIQUID DEPTH = 30"
 3. 4" INLET TEE BAFFLE DISCHARGE = 6" BELOW LIQUID LEVEL
 4. 4" OUTLET TEE BAFFLE INTAKE = 25% TO 50% OF LIQUID DEPTH
 5. INLET FLOW LINE MUST BE A MINIMUM OF 2" HIGHER THAN THE OUTLET FLOW LINE.

PROPRIETARY AND CONFIDENTIAL

THIS INFORMATION CONTAINED IN THE DRAWING IS THE SOLE PROPERTY OF CLEARSTREAM. ANY REPRODUCTION IN PART OR AS A WHOLE WITHOUT THE WRITTEN PERMISSION OF CLEARSTREAM IS PROHIBITED.

DRAWN BY RC	DATE 5-8-21
CHECKED BY	DATE
SCALE: NTS	SHEET 1 OF 1

TITLE:
500DAST

DWG. NO.
500DAST rev2

CLEARSTREAM®
WASTEWATER SYSTEMS, INC.
RESIDENTIAL • COMMERCIAL • MARINE

P.O. Box 7568 Beaumont, Texas 77726

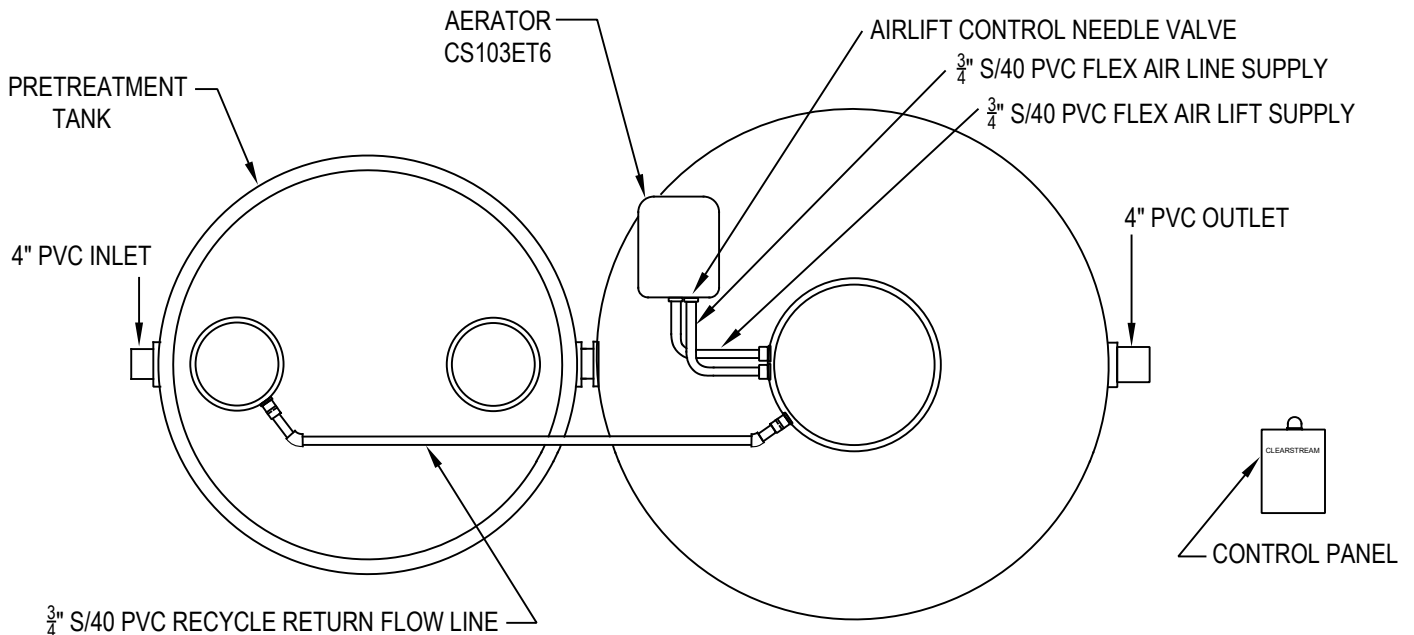

PLAN

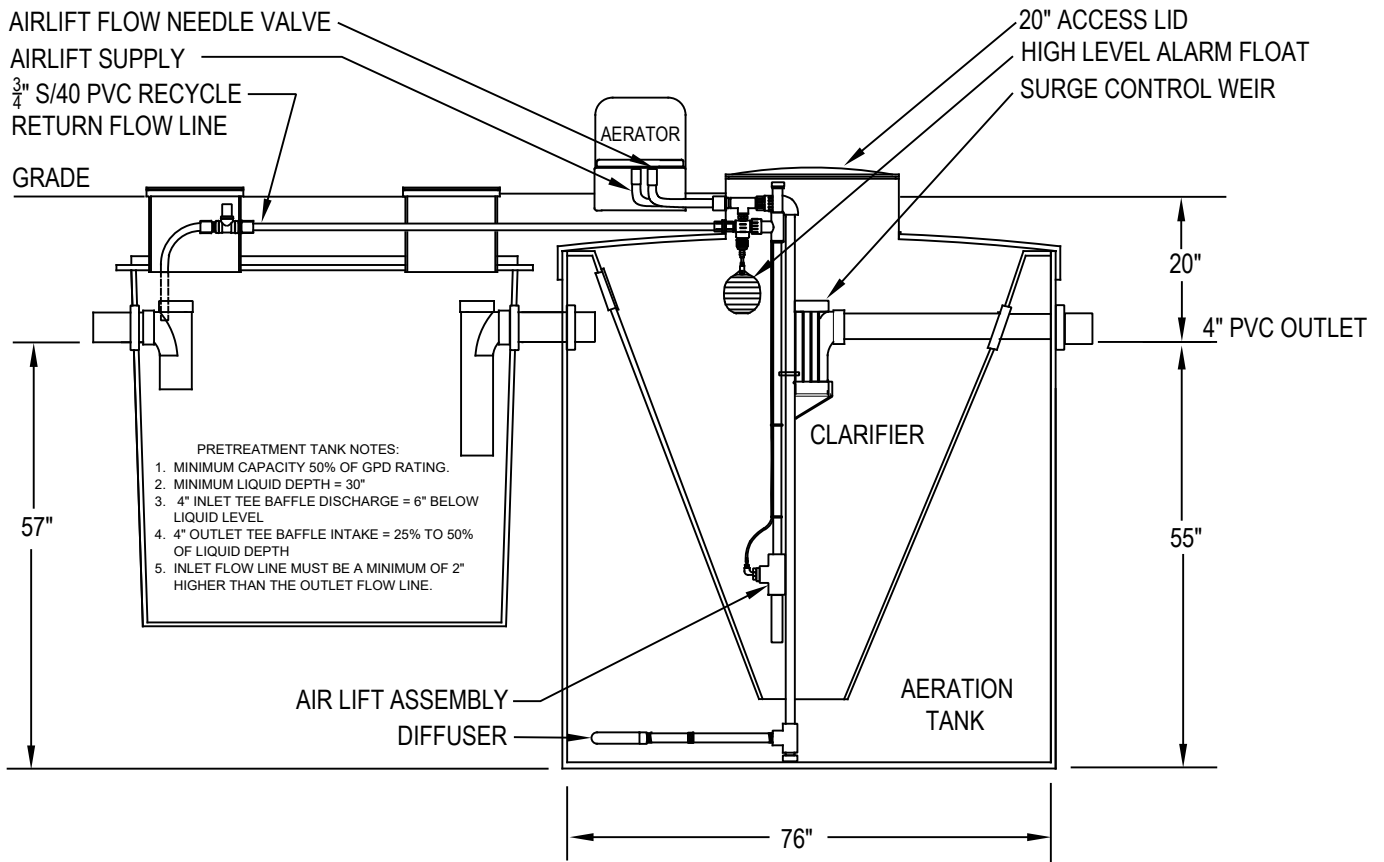

SECTION

- PRETREATMENT TANK NOTES:**
1. MINIMUM CAPACITY 50% OF GPD RATING.
 2. MINIMUM LIQUID DEPTH = 30"
 3. 4" INLET TEE BAFFLE DISCHARGE = 6" BELOW LIQUID LEVEL
 4. 4" OUTLET TEE BAFFLE INTAKE = 25% TO 50% OF LIQUID DEPTH
 5. INLET FLOW LINE MUST BE A MINIMUM OF 2" HIGHER THAN THE OUTLET FLOW LINE.

PROPRIETARY AND CONFIDENTIAL
 THE INFORMATION CONTAINED IN THIS DRAWING IS THE SOLE PROPERTY OF CLEARSTREAM. ANY REPRODUCTION IN PART OR AS A WHOLE WITHOUT THE WRITTEN PERMISSION OF CLEARSTREAM IS PROHIBITED.

DRAWN BY RC	DATE 6/05/2021
CHECKED	DATE
SCALE NTS	SHEET 1 OF 1

600DA

DWG. NO.
600DA rev3

P.O. Box 7568 Beaumont, Texas 77726-7568

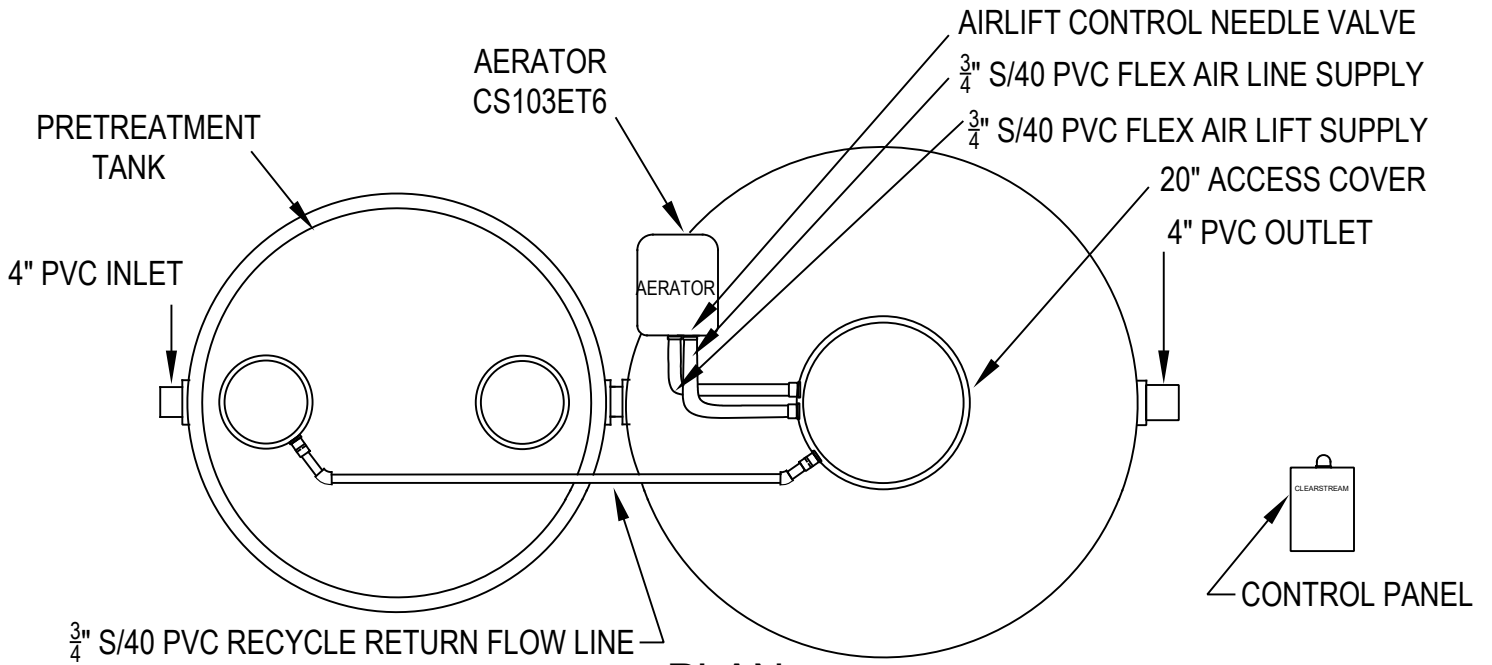

PLAN

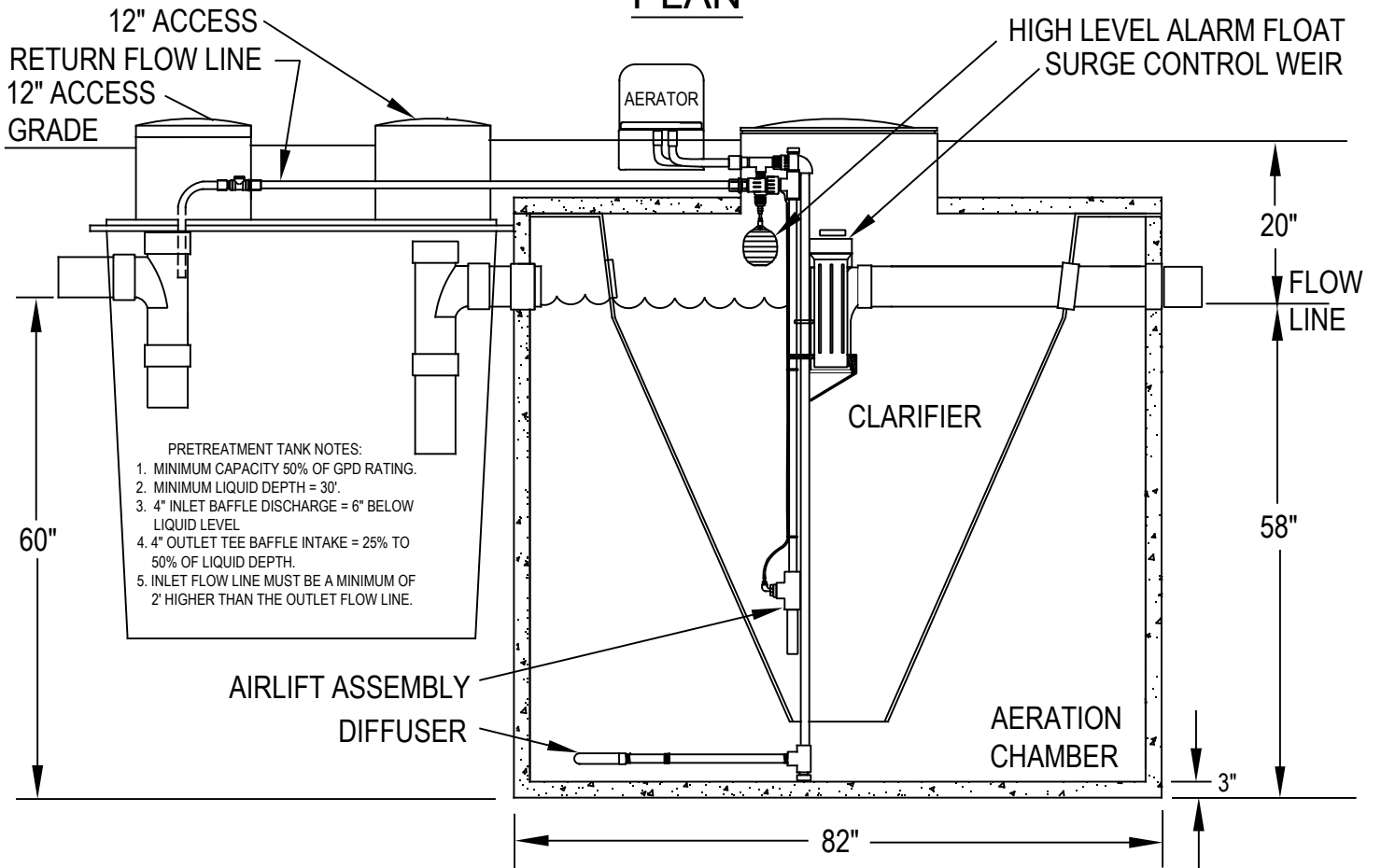

SECTION

PROPRIETARY AND CONFIDENTIAL THE INFORMATION CONTAINED IN THIS DRAWING IS THE SOLE PROPERTY OF CLEARSTREAM. ANY REPRODUCTION IN PART OR AS A WHOLE WITHOUT THE WRITTEN PERMISSION OF CLEARSTREAM IS PROHIBITED.	DRAWN BY RC	DATE 6/05/2021	600DAC DWG. NO. 600DAC rev4	 RESIDENTIAL · COMMERCIAL · MARINE	
	REVISED	DATE 6/10/2021			P.O. Box 7568 Beaumont, Texas 77726-7568
	SCALE NTS	SHEET 1 OF 1			

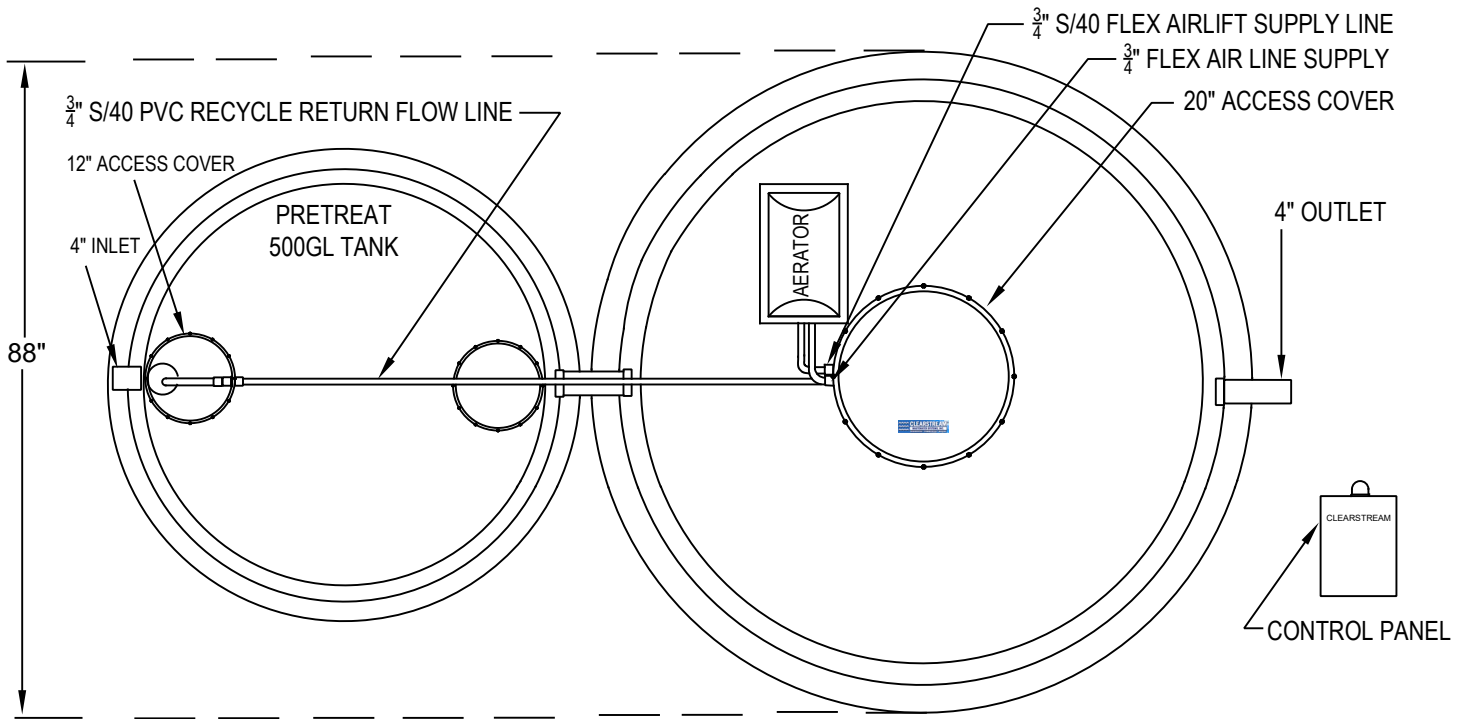

PLAN

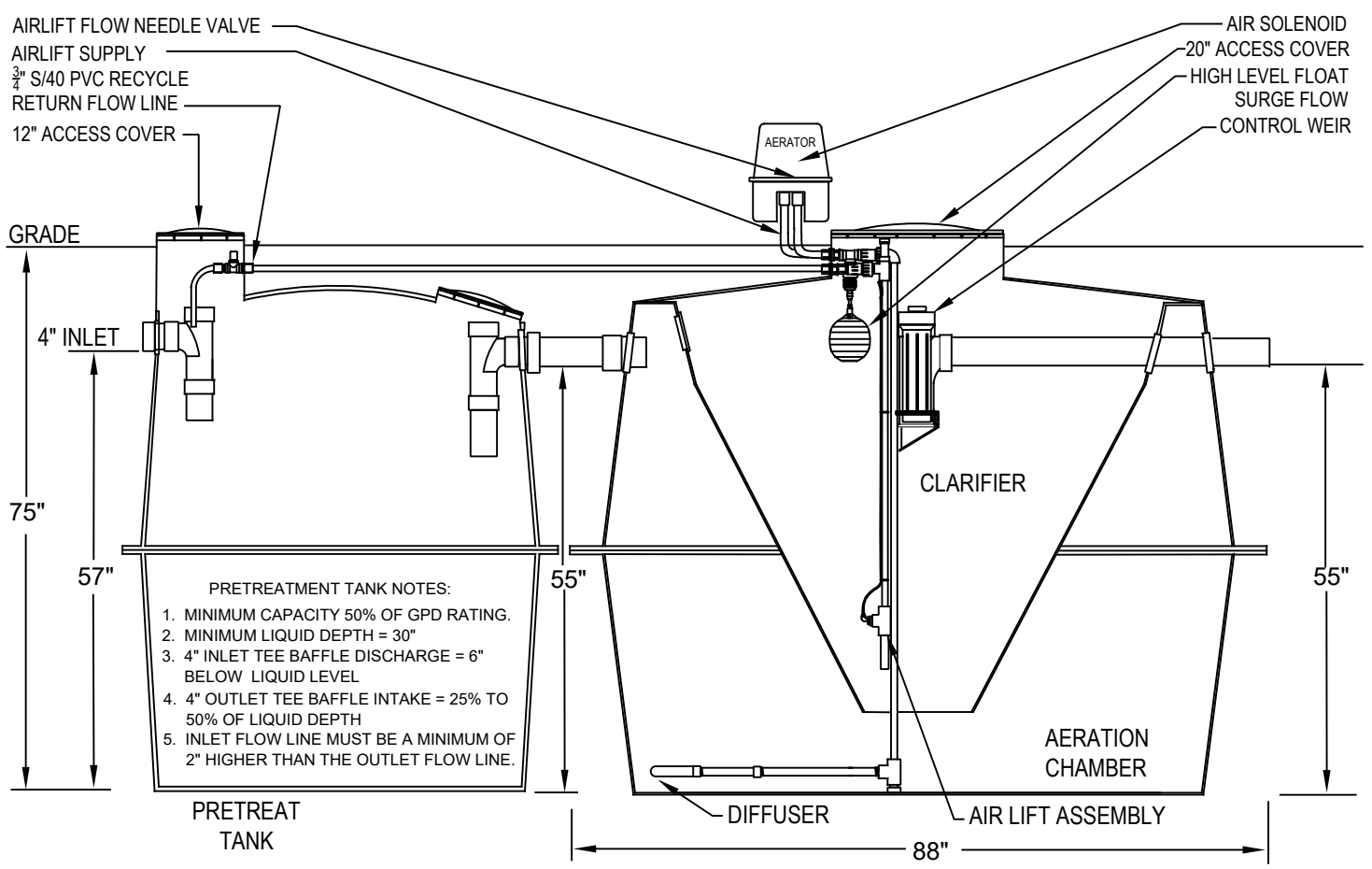

SECTION

- PRETREATMENT TANK NOTES:**
1. MINIMUM CAPACITY 50% OF GPD RATING.
 2. MINIMUM LIQUID DEPTH = 30"
 3. 4" INLET TEE BAFFLE DISCHARGE = 6" BELOW LIQUID LEVEL
 4. 4" OUTLET TEE BAFFLE INTAKE = 25% TO 50% OF LIQUID DEPTH
 5. INLET FLOW LINE MUST BE A MINIMUM OF 2" HIGHER THAN THE OUTLET FLOW LINE.

PROPRIETARY AND CONFIDENTIAL

THIS INFORMATION CONTAINED IN THE DRAWING IS THE SOLE PROPERTY OF CLEARSTREAM. ANY REPRODUCTION IN PART OR AS A WHOLE WITHOUT THE WRITTEN PERMISSION OF CLEARSTREAM IS PROHIBITED.

DRAWN BY RC	DATE 10/24/2020
REVISED: RC	DATE 6/10/2021
SCALE: NTS	SHEET 1 OF 1

DWG. NO.	600DAT
DWG. NO.	600DAT rev2

CLEARSTREAM®
WASTEWATER SYSTEMS, INC.
RESIDENTIAL · COMMERCIAL · MARINE

P.O. Box 7568 Beaumont, Texas 77726

NOTE: AERATORS MAY BE INSTALLED NO MORE THAN 100' FROM AERATION TANKS

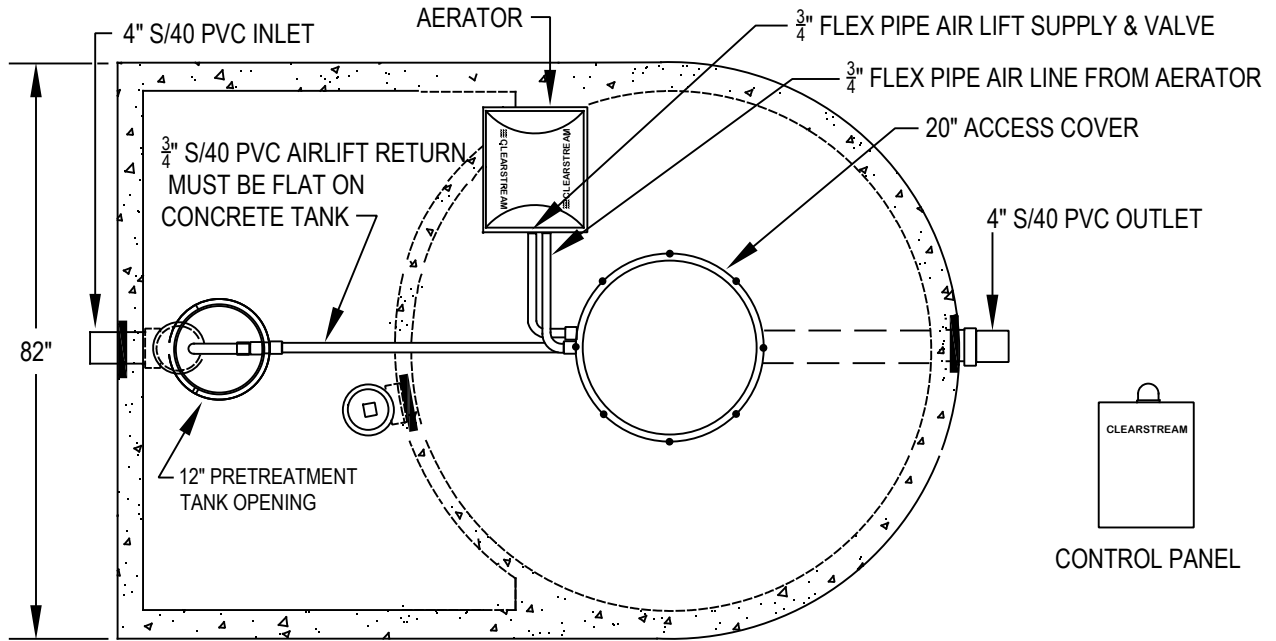

PLAN

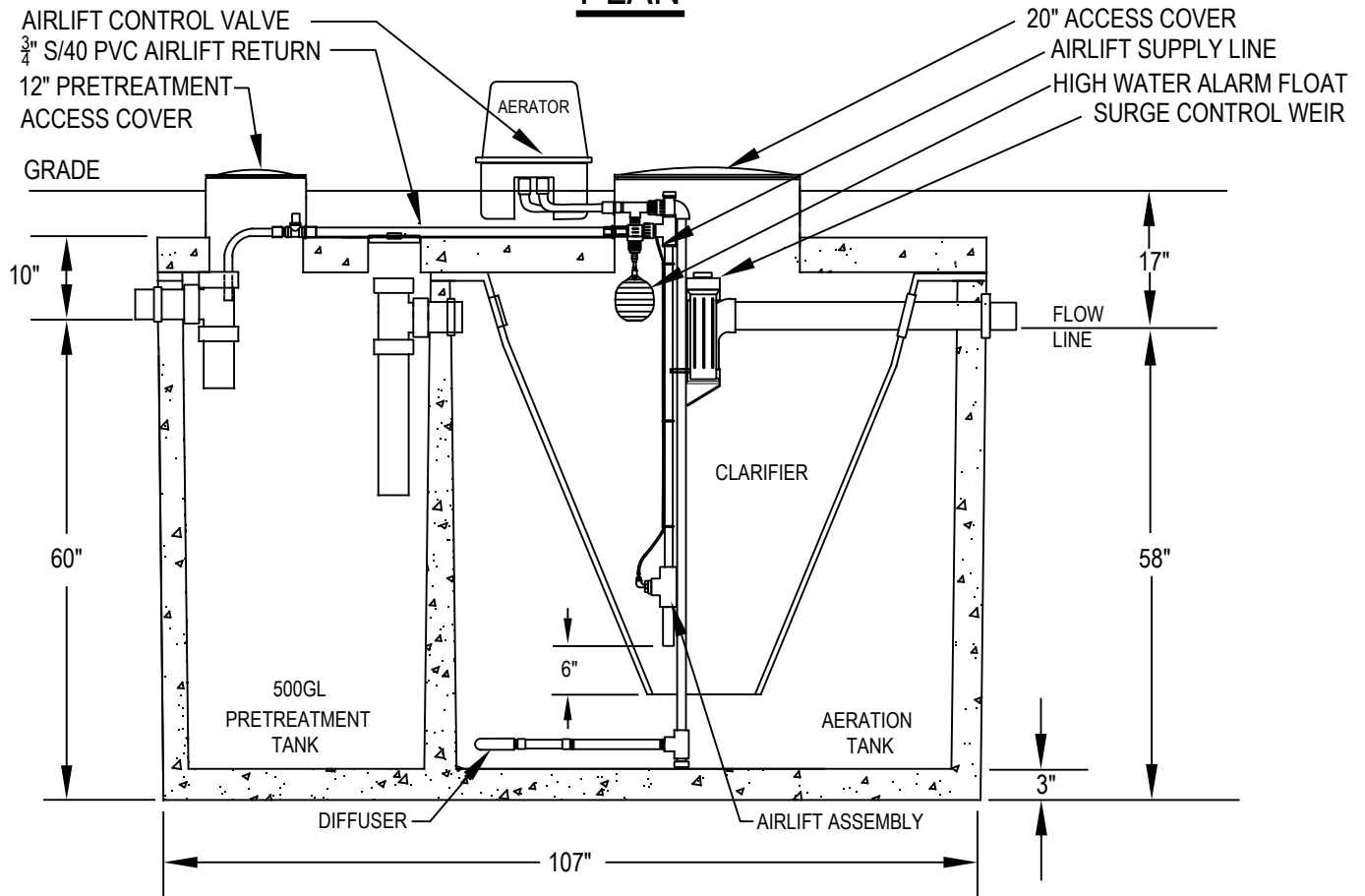

SECTION

PROPRIETARY AND CONFIDENTIAL
THIS INFORMATION CONTAINED IN THE DRAWING IS THE SOLE PROPERTY OF CLEARSTREAM. ANY REPRODUCTION IN PART OR AS A WHOLE WITHOUT THE WRITTEN PERMISSION OF CLEARSTREAM IS PROHIBITED.

DRAWN BY	DATE
REVISED RC	DATE 1/25/2021
SCALE: NTS	SHEET 1 OF 1

600DAC2	
DWG. NO.	600DAC2 rev2

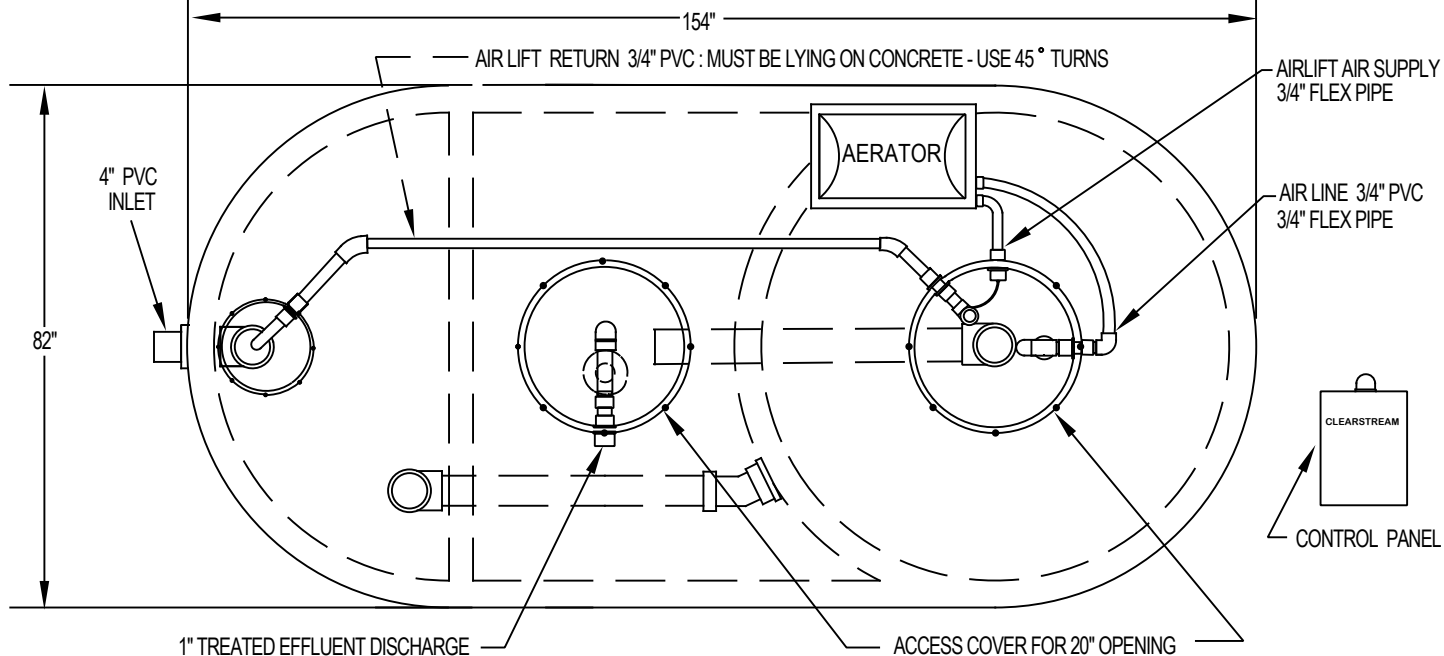

PLAN

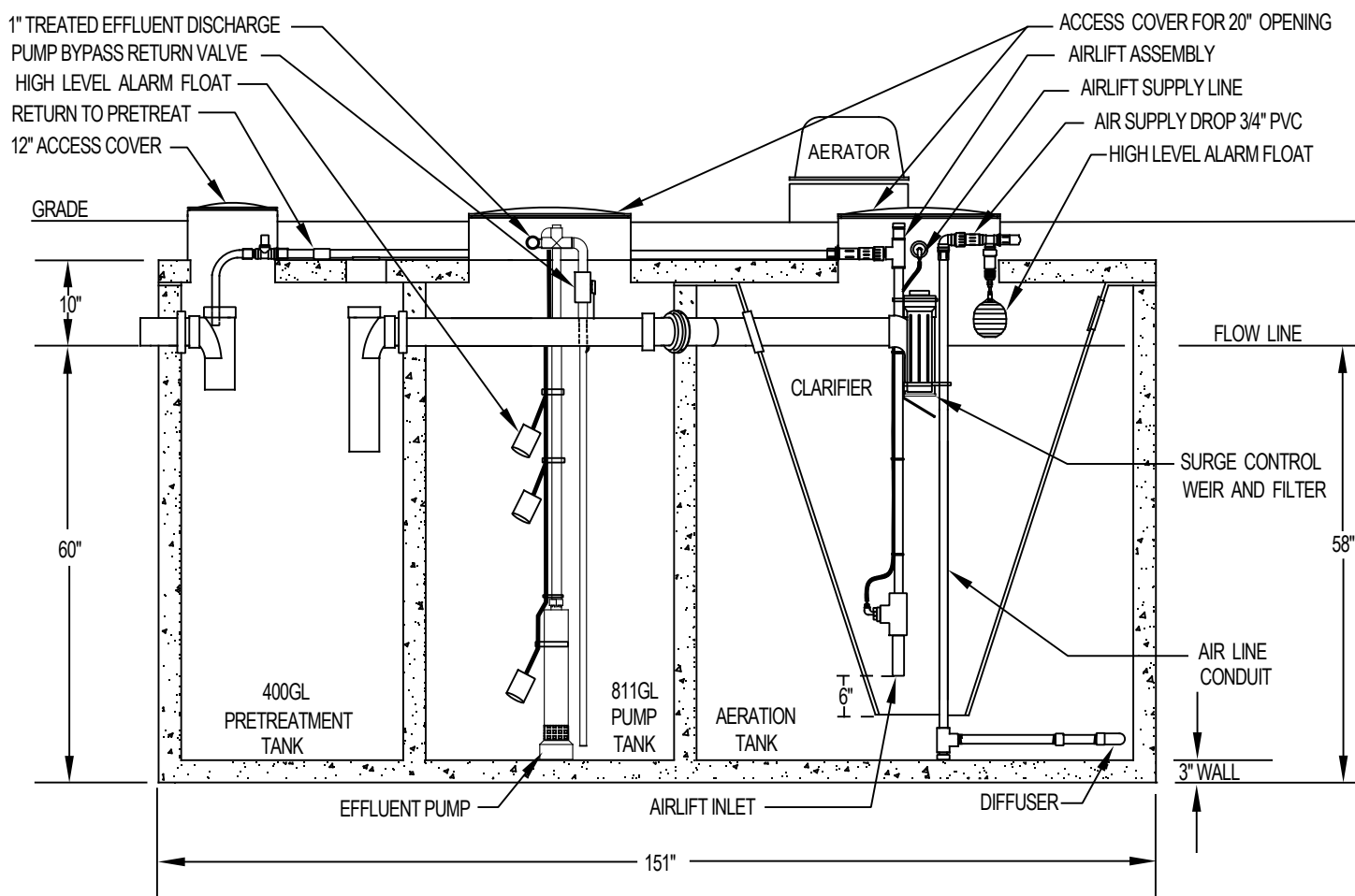

SECTION

PROPRIETARY AND CONFIDENTIAL
 THIS INFORMATION CONTAINED IN THE DRAWING IS THE SOLE PROPERTY OF CLEARSTREAM. ANY REPRODUCTION IN PART OR AS A WHOLE WITHOUT THE WRITTEN PERMISSION OF CLEARSTREAM IS PROHIBITED.

REVISED BY RC	DATE 6/20/2021
CHECKED BY	DATE
SCALE: NTS	SHEET 1 OF 1

600DAC3
 DWG. NO. **600DAC3 rev1**

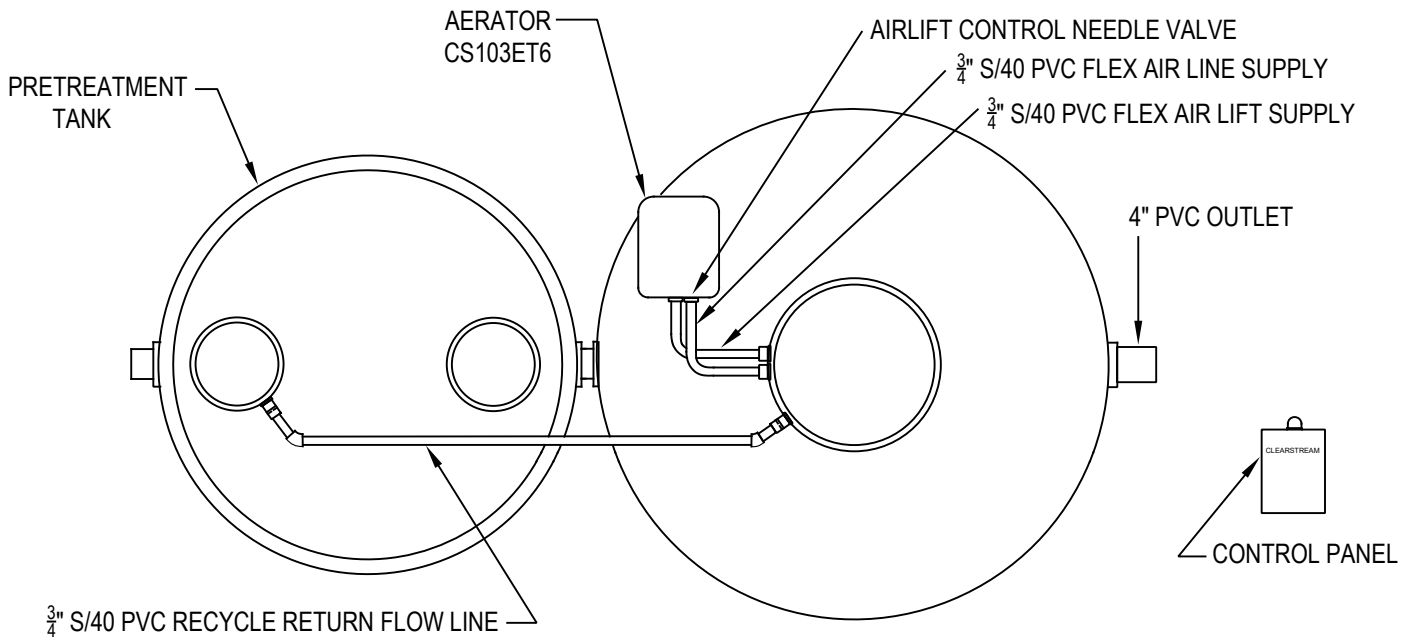

PLAN

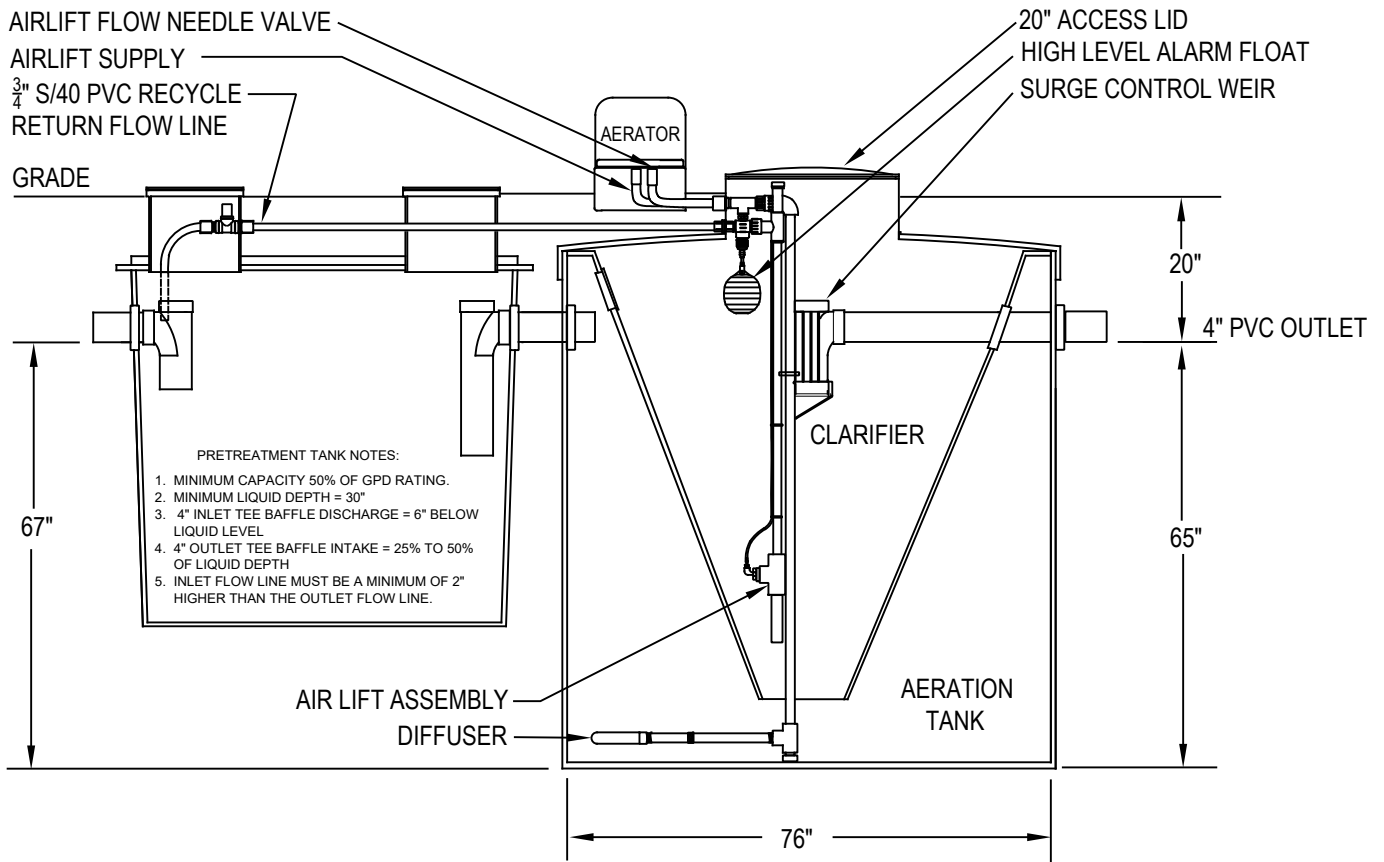

SECTION

PROPRIETARY AND CONFIDENTIAL

THE INFORMATION CONTAINED IN THIS DRAWING IS THE SOLE PROPERTY OF CLEARSTREAM. ANY REPRODUCTION IN PART OR AS A WHOLE WITHOUT THE WRITTEN PERMISSION OF CLEARSTREAM IS PROHIBITED.

DRAWN BY RC	DATE 6/14/2021
CHECKED	DATE
SCALE NTS	SHEET 1 OF 1

750/800DA

DWG. NO.
750-800DA rev3



P.O. Box 7568 Beaumont, Texas 77726-7568

NOTE: AERATORS MAY BE INSTALLED NO MORE THAN 100' FROM AERATION TANKS

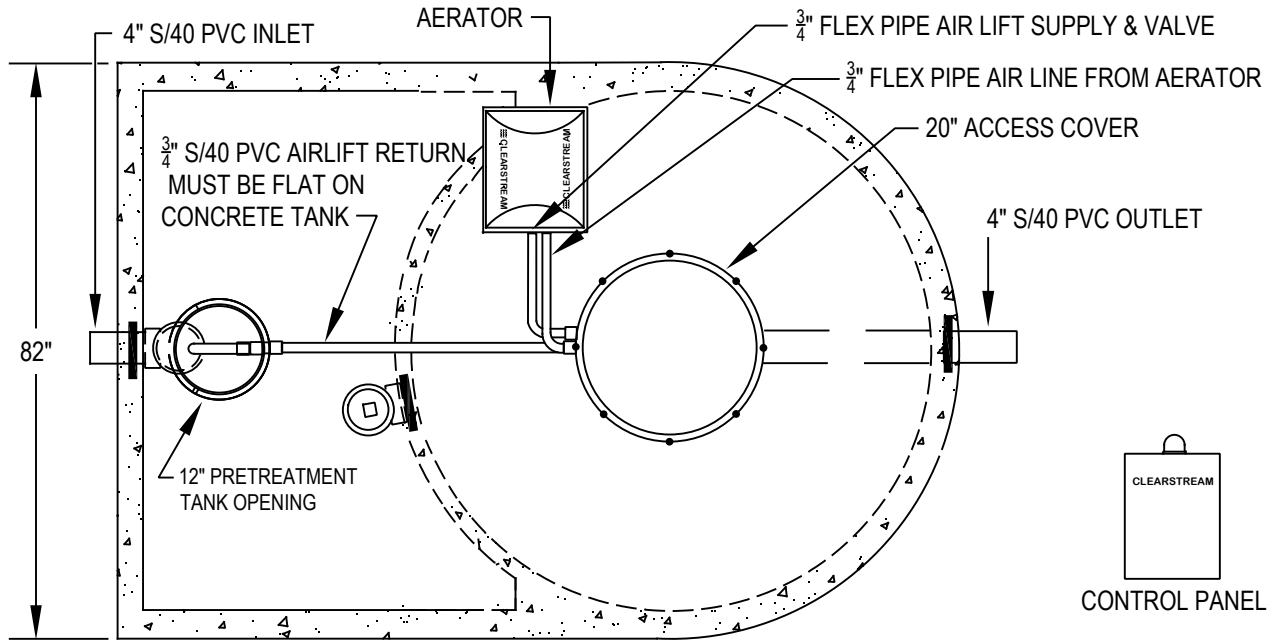

PLAN

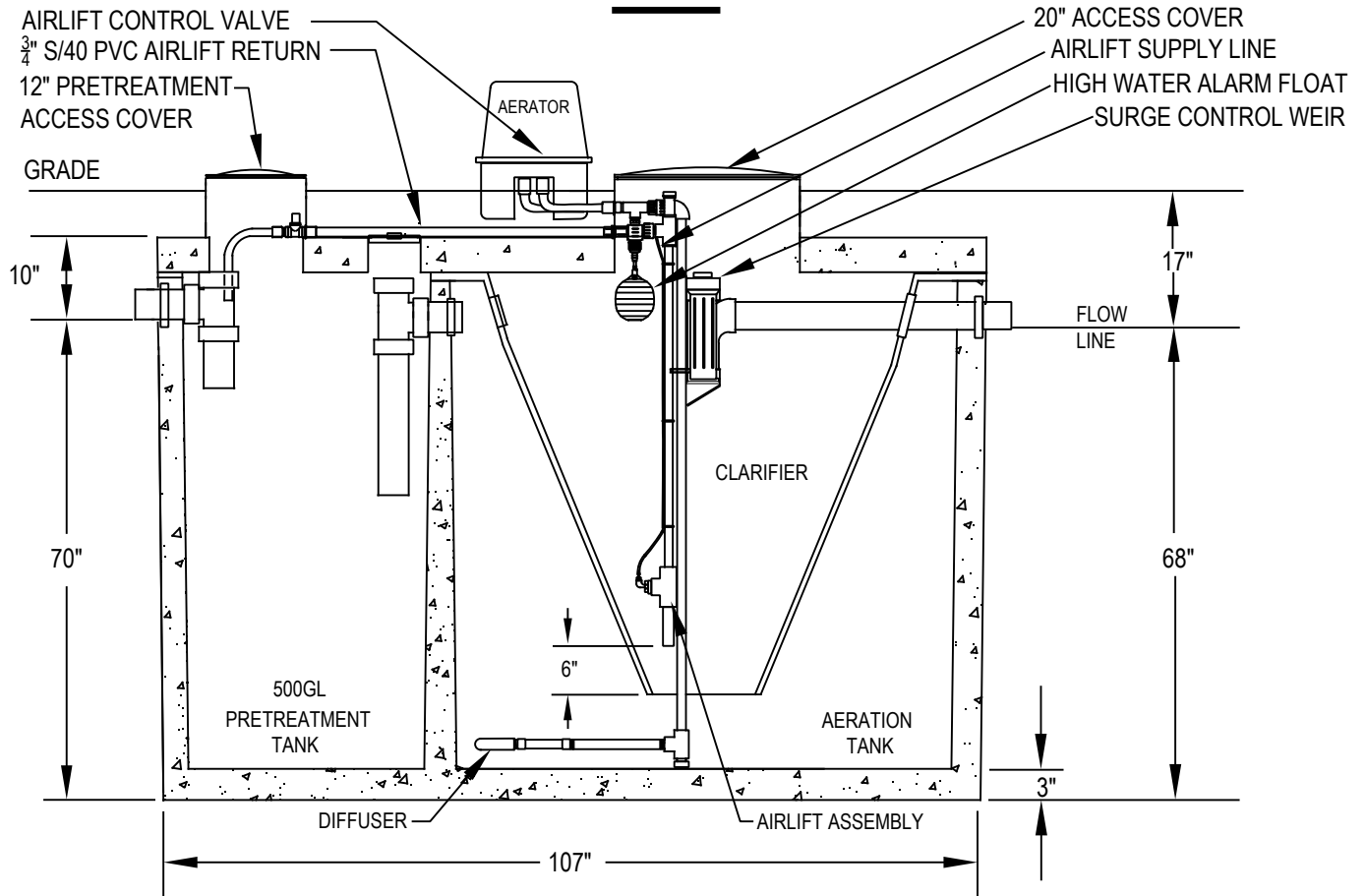

SECTION

PROPRIETARY AND CONFIDENTIAL
THIS INFORMATION CONTAINED IN THE DRAWING IS THE SOLE PROPERTY OF CLEARSTREAM. ANY REPRODUCTION IN PART OR AS A WHOLE WITHOUT THE WRITTEN PERMISSION OF CLEARSTREAM IS PROHIBITED.

DRAWN BY RC	DATE
REVISED RC	DATE 6/15/2021
SCALE: NTS	SHEET 1 OF 1

750/800DAC2	
DWG. NO.	750-800DAC2 rev3

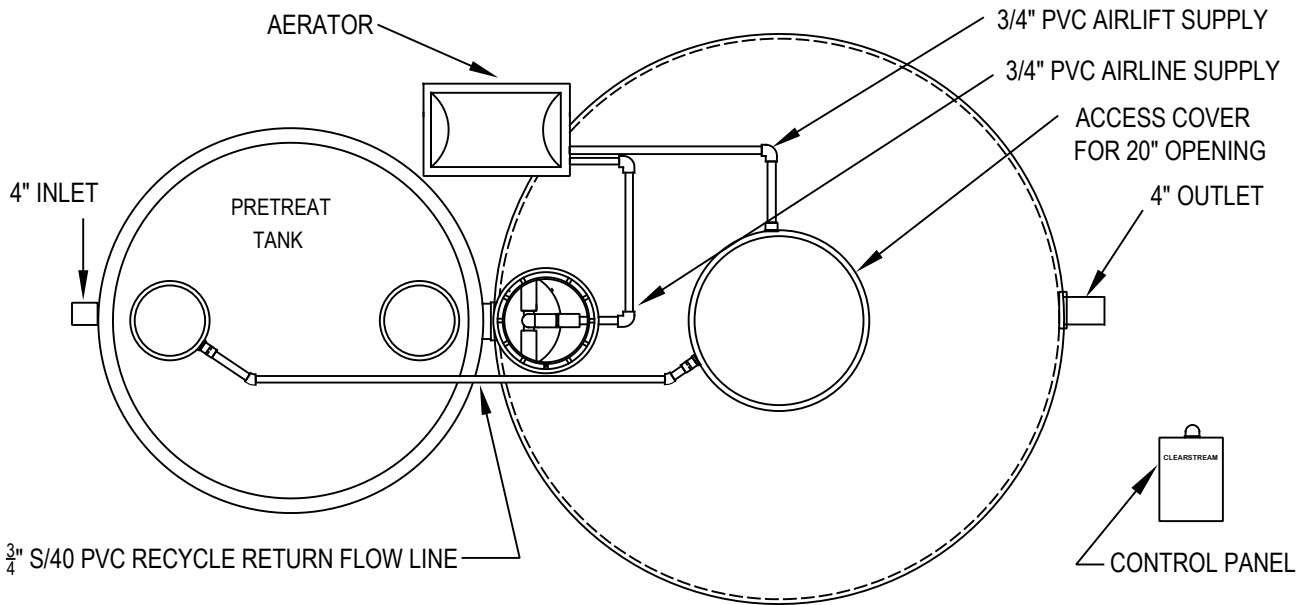

PLAN

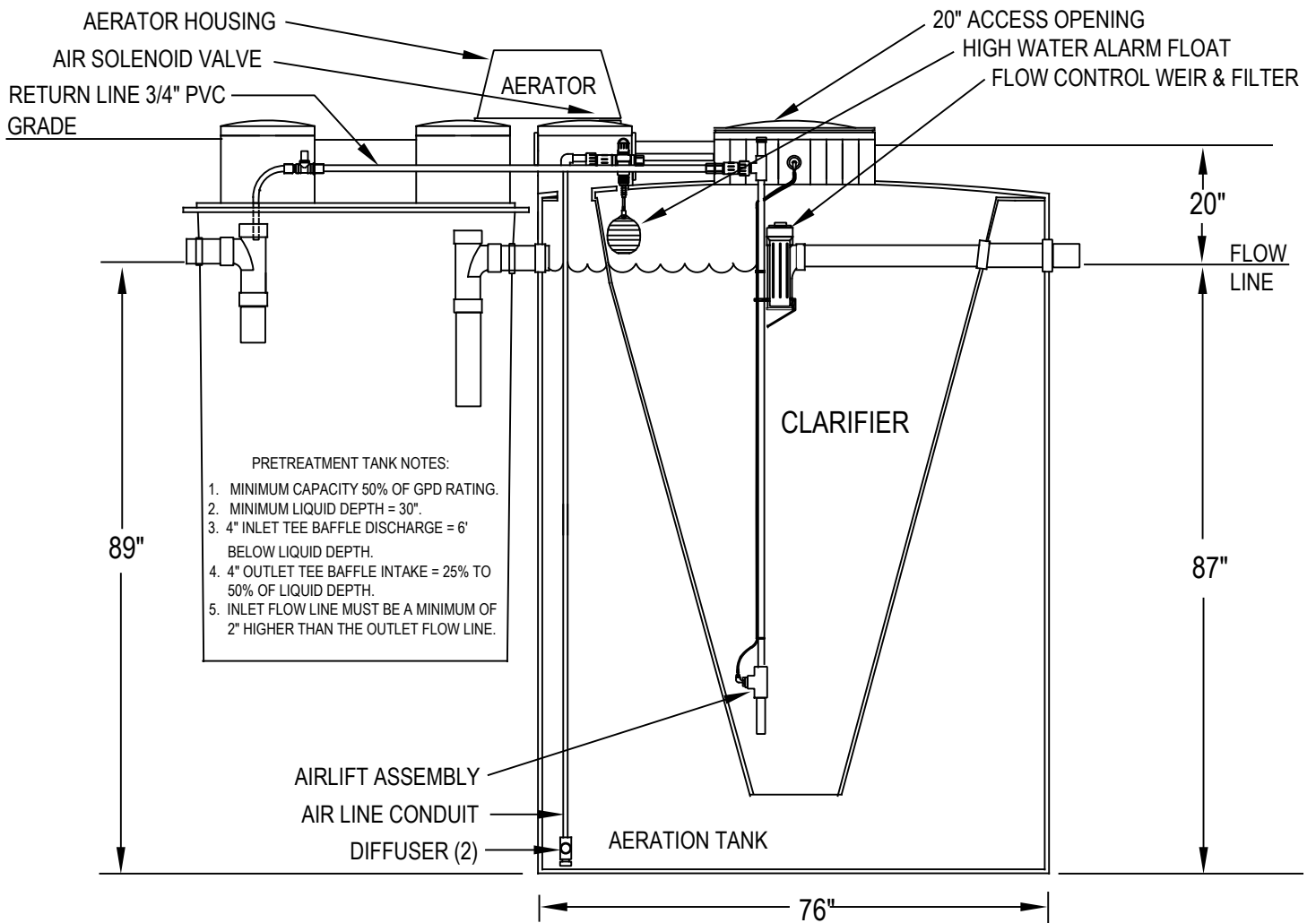

- PRETREATMENT TANK NOTES:
1. MINIMUM CAPACITY 50% OF GPD RATING.
 2. MINIMUM LIQUID DEPTH = 30".
 3. 4" INLET TEE BAFFLE DISCHARGE = 6" BELOW LIQUID DEPTH.
 4. 4" OUTLET TEE BAFFLE INTAKE = 25% TO 50% OF LIQUID DEPTH.
 5. INLET FLOW LINE MUST BE A MINIMUM OF 2" HIGHER THAN THE OUTLET FLOW LINE.

SECTION

PROPRIETARY AND CONFIDENTIAL

THIS INFORMATION CONTAINED IN THE DRAWING IS THE SOLE PROPERTY OF CLEARSTREAM. ANY REPRODUCTION IN PART OR AS A WHOLE WITHOUT THE WRITTEN PERMISSION OF CLEARSTREAM IS PROHIBITED.

DRAWN BY RC	DATE 03/16/2020
CHECKED BY	DATE 6/15/2021
SCALE: NTS	SHEET 1 OF 1

1000DA w/pre

DWG. NO. **1000DA-pre-rev1**

P.O. Box 7568 Beaumont, Texas 77726

NOTE:

AERATOR MAY BE INSTALLED
NO MORE THAN 100' FROM
AERATION TANKS

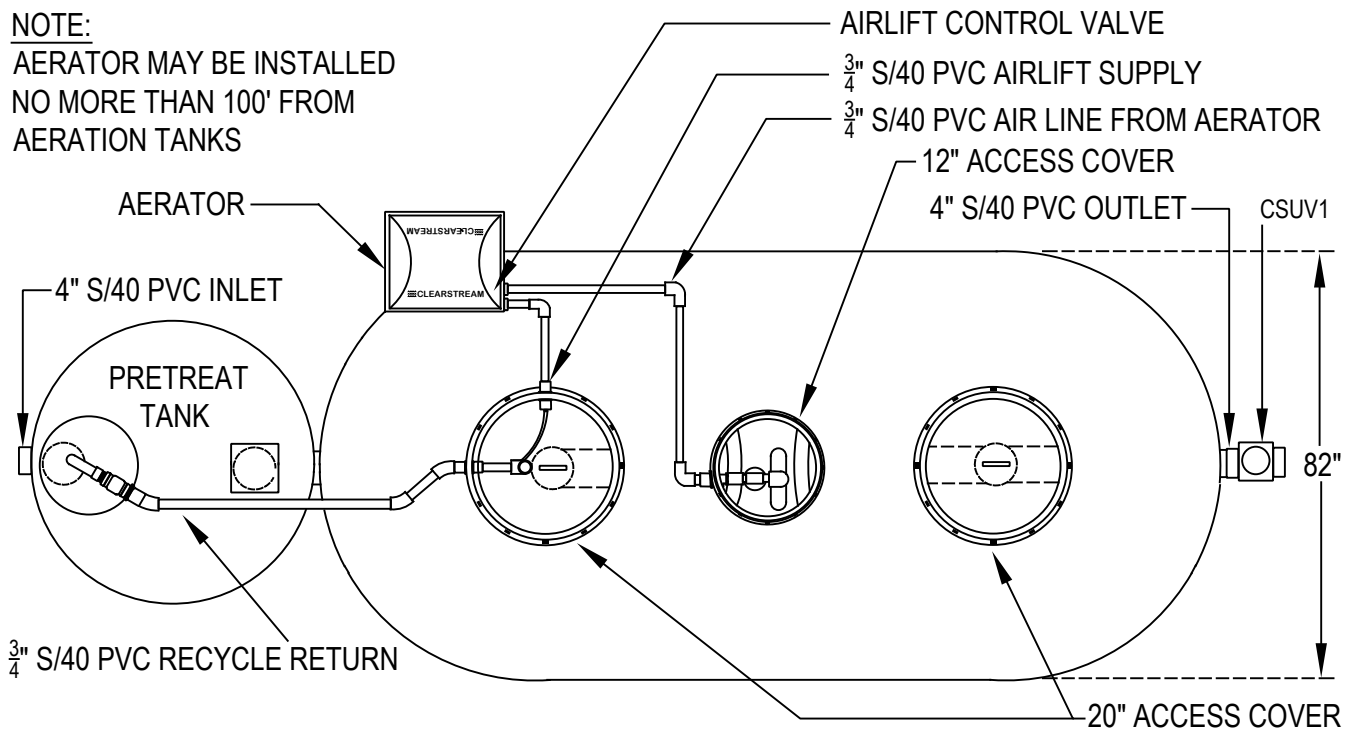

PLAN

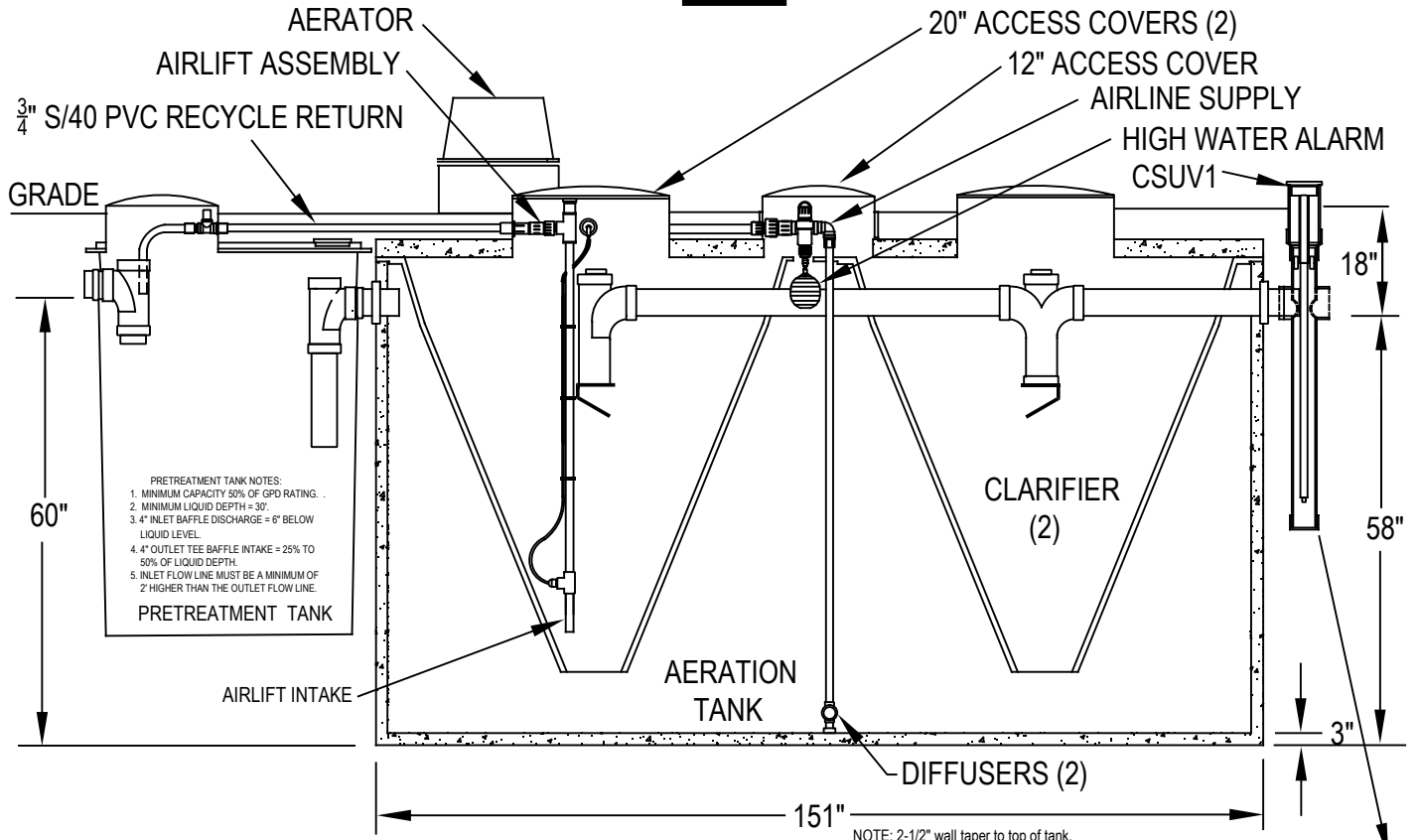

SECTION

NOTE: CSUV1 is optional for Std 40 & 245. Required for Std 350 applications.

<p>PROPRIETARY AND CONFIDENTIAL</p> <p>THIS INFORMATION CONTAINED IN THE DRAWING IS THE SOLE PROPERTY OF CLEARSTREAM. ANY REPRODUCTION IN PART OR AS A WHOLE WITHOUT THE WRITTEN PERMISSION OF CLEARSTREAM IS PROHIBITED.</p>	<p>DRAWN BY RC</p>	<p>DATE 6/17/2021</p>	<p>1200DACD</p>	<p>CLEARSTREAM® WASTEWATER SYSTEMS, INC. RESIDENTIAL • COMMERCIAL • MARINE</p>
	<p>REVISED</p>	<p>DATE 7/23/2021</p>		
	<p>SCALE: NTS</p>	<p>SHEET 1 OF 1</p>	<p>DWG. NO. 1200DACD</p>	

PARTS LIST AND FLOW DIAGRAM: MODEL 500DA

PART NAME:	PART NUMBER:		
1. AIR SUPPLY LINE ASSEMBLY	CS-101		
2. HIGH WATER ALARM FLOAT	CS-102		
3. AERATOR	CS-103ET6		
4. NAMEPLATE	CS-107		
5. ACCESS COVER	CS-108		
6. TAMPER RESISTANT BOLT	CS-109		
7. ATU TANK	CS-110		
8. DIFFUSER	CS-113		
9. ALARM PANEL	CS-114		
10. PLASTIC 12' DIA. EXTENSION RISER	CS-116A		
11. PLASTIC 20' DIA. EXTENSION RISER	CS-116		
12. AIR SOLENOID VALVE (LOCATED INSIDE HOUSING)	CS-130		
13. AIR FLOW CONTROL VALVE (INSIDE HOUSING)	CS-131		
14. AERATOR POLYETHYLENE HOUSING	CS-106		
15. AIRLIFT RECYCLE ASSEMBLY	CS-132		
16. GAS BAFFLE	CS-117	17. FLOW CONTROL WEIR	CS-111
17. FLOW CONTROL WEIR	CS-111		

COMPONENT PARTS MAY BE OBTAINED FROM YOUR LOCAL SERVICING DEALER

OR



PO BOX 705 BEAUMONT, TX 77726 800-586-3656

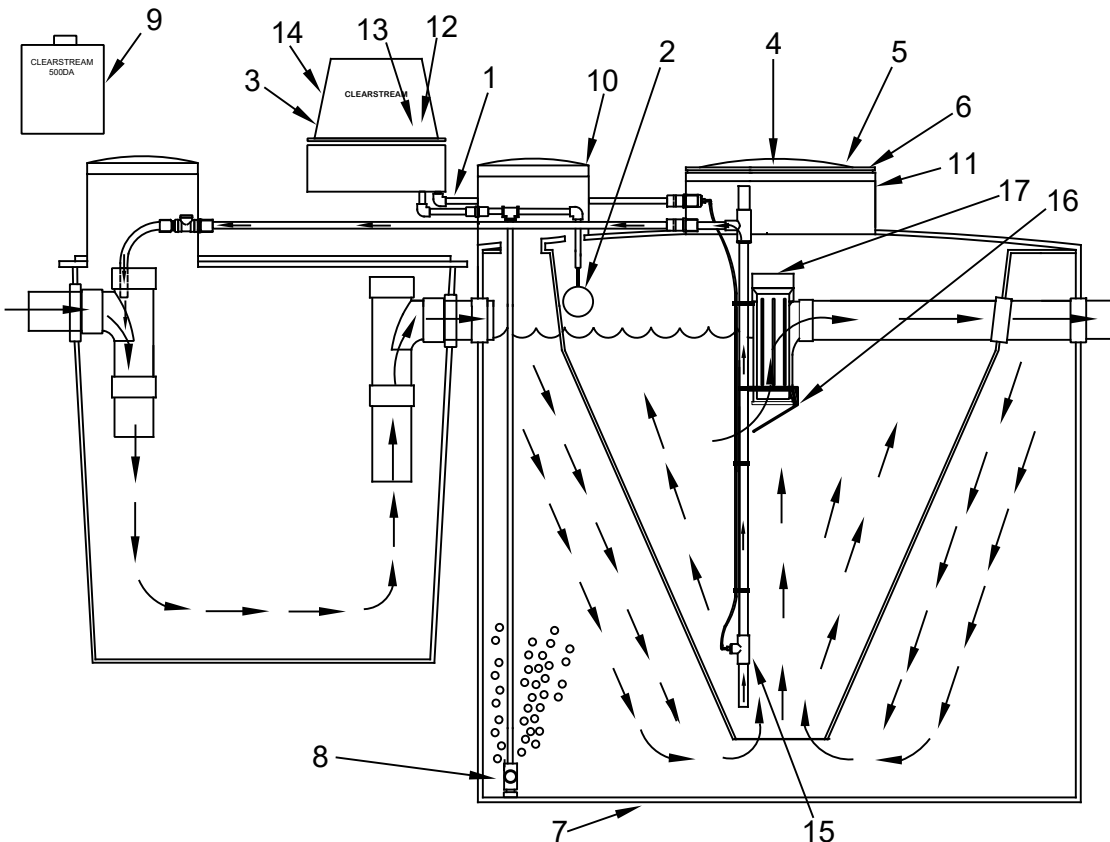

SPECIFICATIONS:

Model 500DA, DAST, DAC, DASC:

Loading

Aerator CS103ET6

Control Panel (Model CS114)

Electrical

500 GPD

1.25 lbs. BOD

2.65 scfm

Raintight

115v/60hz/1ph.

Model 600DA, DAT, DAC, DAC2, DAC3:

Loading

Aerator CS103ET6

Control Panel (Model CS114)

Electrical

600 GPD

1.5 lbs. BOD

2.65 scfm

Raintight

115v/60hz/1ph.

Model 750/800DA, DAC2:

Loading

Aerator CS103FT

Control Panel (Model CS114)

Electrical

750/800 GPD

2.0 lbs. BOD

4.1 scfm

Raintight

115v/60hz/1ph.

Model 1000DA:

Loading

Aerator CS10GT

Control Panel (Model CS114)

Electrical

1000 GPD

2.5 lbs. BOD

4.8 scfm

Raintight

115v/60hz/1ph.

MODEL 1200DACD:

Loading

Aerator CS103GT

Control Panel (Model CS114)

Electrical

1200 GPD

3.0 lbs. BOD

5.3 scfm

Raintight

115v/60hz/1ph.

Pretreatment Tank:

1. Minimum capacity 50% of GPD rating.
2. Minimum liquid depth = 30".
3. 4" inlet tee baffle discharge = 6" below liquid level.
4. 4" outlet tee baffle intake = 25% to 50% of liquid depth.
5. Inlet flow line must be a minimum of 2" higher than outlet flow line.

LIMITED WARRANTY

Clearstream Wastewater Systems, Inc. warrants each Clearstream Aerobic Wastewater Treatment System to be free from defects in material and workmanship for a period of two (2) years from the date of sale to the original retail consumer when properly registered with Clearstream. Clearstream's sole obligation under this warranty is as follows: Clearstream shall fulfill this warranty by repairing or exchanging any component part, F.O.B. Factory, that shows evidence of defects, provided said component part has been paid for, warrantee has notified Clearstream of the defect complained of and the component is returned through an authorized Purchaser, transportation prepaid. There is no informal dispute settlement available under this LIMITED WARRANTY.

No warranty is made as to the field performance of any system. This LIMITED WARRANTY applies only to the parts manufactured by Clearstream and does not include any portion of the plumbing, drainage, disposal system or installation of the systems. Site specific designs of treatment and disposal systems, including treatment plant and disposal system sizing is not the responsibility of Clearstream and is not covered by this LIMITED WARRANTY. Accessories supplied by Clearstream, but manufactured by others, are warranted only to the extent of and by the terms and conditions of the original manufacturer's warranty. In no event shall Clearstream be responsible for delay or damages of any kind or character resulting from, or caused directly or indirectly by, defective component or materials manufactured by others.

Recommendations for special applications will be based on the best available expertise of Clearstream and published industry information. Such recommendations do not constitute a warranty of satisfactory performance.

The LIMITED WARRANTY extends to the original retail consumer of the product. As herein, original retail consumer is defined as the purchaser who first has the plant installed, or in the case of a system designed for non-permanent installation, the purchaser who first uses the system. It is the purchaser's, or any sub-vendee's, obligation to make known to any other consumer the terms and conditions of this warranty.

This warranty is a LIMITED WARRANTY and no claim of any nature shall be made against Clearstream unless and until the original retail consumer, or his legal representative, notifies Clearstream in writing of the defect complained of and delivers the product and/or defective part(s), freight prepaid, to Clearstream or an authorized service station.

Clearstream reserves the right to revise, change, or modify the construction and design of the Clearstream Aerobic Treatment System, or any component part or parts thereof, without incurring any obligation to make such changes or modifications in equipment previously sold. Clearstream also reserves the right, in making replacements of component parts under this warranty, to furnish a component which, in its judgement is equivalent to the part replaced.

To the extent that the LIMITED WARRANTY statements herein are inconsistent with the locality where Purchaser used the Clearstream system, the warranties shall be deemed to be modified consistent with such local law. Under such local law, certain limitations may not apply. For example, some states in the United States and some jurisdictions outside the United States may: (i) preclude the disclaimers and limitations of these warranties from limiting the rights of a consumer; (ii) otherwise restrict the ability of a manufacturer to make such disclaimers or to impose such limitations; or (iii) grant the consumer additional legal rights, specify the duration of implied warranties which the manufacturer cannot disclaim, or prohibit limitations on how long an implied warranty lasts.

In no event and under no legal theory, including without limitation, tort, contract, or strict product liability, shall Clearstream or any of its suppliers be liable to the other party for any indirect, special, incidental, or consequential damages of any kind, including without limitation, damages for loss of goodwill, or any other kind of commercial damage, even if the other party has advised Clearstream of the possibility of such damages.

TWO YEAR INITIAL SERVICE POLICY

Date _____

Our firm, _____, will inspect and service your Clearstream System for the first two years from the date of installation. There will be _____ inspections made each year for this initial two year

period. Effluent quality inspection will include a visual inspection for color, turbidity, sludge build up, scum overflow, and odor. Mechanical and electrical inspection and service include: inspecting aerator, air filter, and alarm panel and replacing or repairing any component not found to be functioning correctly.

Upon expiration of this policy, our firm will offer a continuing service policy on a yearly basis to cover labor for normal maintenance and repairs on a year by year basis.

Violations of warranty include: shutting off the electric current to the system for more than 24 hours, disconnecting the alarm system, restricting ventilation to the aerator, overloading the system above its rated capacity, or introducing excessive amounts of harmful matter into the system, or any other form of unusual abuse.

**THIS POLICY DOES NOT INCLUDE PUMPING
SLUDGE FROM UNIT IF NECESSARY.**

Service Dealer:

Owner

**CLEARSTREAM WASTEWATER
SYSTEMS, INC.**

P. O. Box 7568 Beaumont, Texas 77726-7568

Phone:(409) 755-1500

Fax: (409) 755-6500

www.clearstreamsystems.com

Copyright: 7/2013

Printed: 07/21/2015 Revised: 4/25/2023